

LEGAL DESCRIPTION:

CLASS:

-----		CSR'S	.00
			CODE VALUE ACRES
GROSS	CURRENT		
ROADS	LAND	207,640	
D.D.	BLDG		
R.R.	DWLG	295,420( 1)	
MISC			
	TOTAL	503,060	
NET			

02-01 R RESIDENTIAL  
 SL HAYES S-W S SD  
 1ST PLAT BEL AIR  
 BEACH

=====		=====	=====
		YEAR	2010
	LAND	207,640	
	BLDG		
	DWLG	295,420( 1)	
	TOTAL	503,060	
	NET TX		

DEED HOLDER:	DATE REFER	CONTRACT HOLDER:	DATE REFER	YEAR	2009
MASON THERESA A	06302010 4			LAND	207,640
MASON WILLIAM C REV TRUST				BLDG	
139 MALLARD				DWLG	295,420( 1)
STORM LAKE IA 50588				TOTAL	503,060
				NET TX	

-----		-----	-----	-----	-----
		YEAR	2008		
JENSEN NATHAN A	03312003 3	LAND	136,320		
JENSEN NANCY		BLDG			
1117 EMERALD DR		DWLG	367,560( 1)		
STORM LAKE IA 50588		TOTAL	503,880		
		NET TX			

-----		-----	-----	-----	-----
		YEAR	2007		
CENDANT MOBILITY FINANCIAL CORPORATION	06192002 2	LAND	136,320		
40 APPLE RIDGE		BLDG			
DANBURY CT		DWLG	367,560( 1)		
SEDLACEK JOEL J	1	TOTAL	503,880		
SEDLACEK MARSHA K		NET TX			
P O BOX 522					
STORM LAKE IA					

-----		YEAR	2007		
REMARKS:		LAND	115,530		
1 W.D. 58/558 07-02-92 \$79,500 (D034)		BLDG			
2 W.D. #021863 02-04-02 \$398,750		DWLG	311,490( 1)		
3 W.D. #031208 03-14-03 \$309,000 (D000)		TOTAL	427,020		
4 W.D. #101382 06-04-10 \$445,000		NET TX			

-----		YEAR	2006		
		LAND	115,530		
		BLDG			
		DWLG	311,490( 1)		
		TOTAL	427,020		
		NET TX			

139 MALLARD, STORM LAKE

Deed: **MASON THERESA A, MASON WILLIAM C REV TRUS** Map Area: **HAYES-RES(BEL AIR)**  
 Contract: Route: **915-003-020**  
 CID#: **0942400** Tax Dist: **SL HAYES S-W S SD**  
 DBA: Plat Page:  
 MLS: **14377** Subdiv: **[NONE]**

Checks/Tags:  
 Lister/Date: **LF, 06/30/2008**  
 Review/Date: **TG, 12/02/2008**  
 Entry Status: **Estimated**

RURAL/RESIDENTIAL

Legal: 02-01 SL HAYES S-W S SD 1ST PLAT BEL AIR BEACH

Land

Land Basis	Front	Rear	Side 1	Side 2	R. Lot	SF	Acres								
<b>FF Main</b>	113.00	113.00	155.00	158.00	0.00										
Sub Total						17,684.50	0.406								
<b>Grand Total</b>						17,684.50	0.406								

Sales				Building Permits				Values					
Date	\$ Amount	NUTC	Recording	Date	Number	Tag	\$ Amount	Reason					
06/04/2010	\$445,000	D20.3	101382										
03/14/2003	\$309,000	D0	#031208										
02/04/2002	\$398,750	D0	#021863										
07/02/1992	\$79,500	D34.1	058-558										

Res. Structure		1 of 1		Finish				Plumbing				Addition		Garage	
Occ. Code	101	Ttl Rooms Above #	7	Bedrooms Above #	4	Full Bath	2	Addition	1 of 3	Garage	1 of 1				
Occ. Descr.	Single-Family / Owner Occupied	Ttl Rooms Below #	0	Bedrooms Below #	0	Shower Stall Bath	1	Year Built	1992	Style	Att Frm				
Year Built	1992	Bsmt Fin Area #1	750	Table		Toilet Room		EFA	17	W X L	0' X 0'				
EFA / EFYr	17 / 1992	Bsmt Fin Area #2				Lavatory	2	EFA Year	1992	Area (SF)	876				
Arch. Dsgn	N/A	Bsmt Fin Area #3				Water Closet		Style	2 Sty Frm	Year Built	1992				
Style	1 Story Frame	Foundation	C Blk			Sink	1	Area (SF)	644	EFA	17				
AreaSF/TLA	1,488 / 2,980	Exterior Walls	Wd Lap			Shower Stall/Tub	1	Condition	Normal	EFF Year	1992				
Condition	NML	Roof	Asph / Hip			Mtl St Sh Bath				Condition	NML				
Basement	Full	Interior Finish	DRYWALL/HARDWOOD			Mtl Stall Shower		Bsmt (SF)	644	Condition	NML				
No Bsmt Flr.	0	Flooring	Carp / Ceramic			No Bathroom		NoBsmt Flr(SF)		Bsmt (SF)					
Heat	FHA - Gas	<b>Non-base Heating</b>		<b>Fireplace</b>		Wet Bar		Heat	FHA - Gas	Qtrs Over	None				
AC	Yes	Floor/Wall #	0	Prefab, 1 Sty	1	Whirlpool Bathroom		AC	Yes	Qtrs Over (SF)					
Attic	None	Pipeless #	0			Whirlpool Tub		Attic (SF)		Qtrs AC (SF)					
		Hand Fired (Y/N)	No			No Hot Water Tank		See other pages for more additions.							
		Space Heat #	0			No Plumbing				Door Opnrs					
		<b>Appliances</b>				Sewer & Water Only				Bsmt Stalls					
		Range Unit	Built-In Vacuums			Water Only w/Sink									
		Oven - Single	Intercom System			Hot Tub									
		Oven - Double	Bl Stereo			Bidet									
		Dishwasher				FbglS Service Sink									
		Microwave				Urinal									
		Trash Compactor				Sauna									
		Jennair				W'Pool Bath w/Shower									
		Security System				Water Only									
						No Tub/Shower									



Bldg / Addn	Description	Units	Year
1 of 1	101 — Single-Family / Owner Occupied		
	1 Story Frame	1,488	
#1	Bsmt Fin - Living Qtrs. (Multi) (High)	750 Tbl	
	Base Heat: FHA - Gas		
	Add Central Air	1,488	
#1	Porch: 1S Frame Open	178 SF	
	Deck #1: Concrete Patio-Low	124 SF	
	Deck #2: Wood Deck-Med	415 SF	
	Plumbing	7	
#1	Fireplace: Prefab, 1 Story	1	
	Garage: Att Frame	876 SF	1992
1 of 3 Adtn	2 Story Frame	644 SF	1992
2 of 3 Adtn	1 Story Frame	83 SF	1992
3 of 3 Adtn	1 Story Frame	121 SF	1992

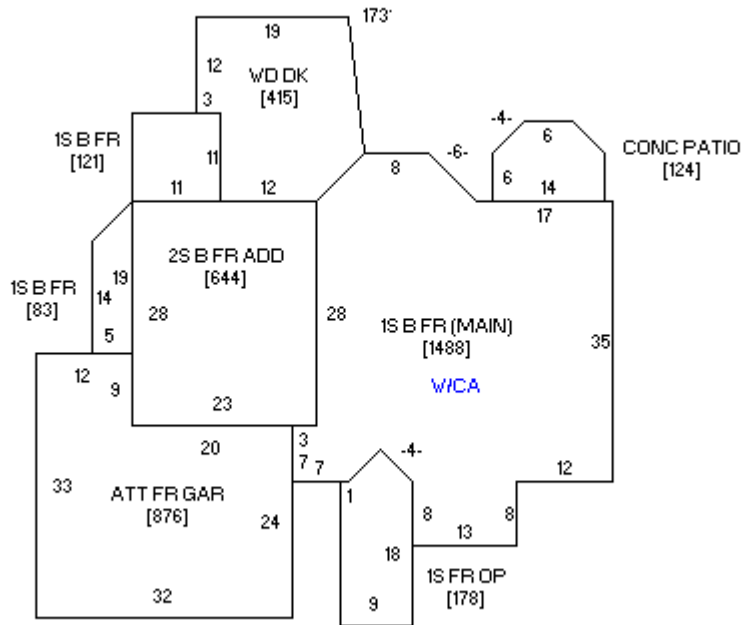



07/14/2008



04/15/1999



06/03/2002