

Pin: 03-27-400-006
Sale Date: 08-26-10
Sale Price: \$155,000
Acres: 7.04 Net
Classification: Change in use
from Ag to Rural Residential

03-27-400-006

#9127.75



LEGAL DESCRIPTION:

CLASS:

27-93-36
S.R.-REMB. LEE
LOT A IN NW SE

A AGRICULTURE

-----		CSR'S	532.00	-----	
				CODE	VALUE ACRES
GROSS	7.61	CURRENT			
ROADS	.57	LAND	9,340		
D.D.		BLDG	6,140(11)		
R.R.		DWLG	83,320(1)		
MISC					
		TOTAL	98,800		
NET	7.04				

=====		=====	=====	=====	
		YEAR	2010	REFER:	1
		LAND	9,340		
		BLDG	6,140(11)		
		DWLG	83,320(1)		
		TOTAL	98,800		
		NET TX			

DEED HOLDER:
GLOVER KALE DAVID
4660 165TH AVE
MARATHON IA 50565

DATE REFER
09302010 2

CONTRACT HOLDER:

DATE REFER
YEAR

LAND	
BLDG	
DWLG	
TOTAL	
NET TX	

LANDSNESS MERLIN J
LANDSNESS PHYLLIS J
4660 165TH AVE
MARATHON IA 50565

YEAR	
LAND	
BLDG	
DWLG	
TOTAL	
NET TX	

REMARKS:
1 2010)SPLIT FROM -001 (09/30/10)
2 WD #102227 08/26/10 \$155,000 (D26)

YEAR	
LAND	
BLDG	
DWLG	
TOTAL	
NET TX	
YEAR	
LAND	
BLDG	
DWLG	
TOTAL	
NET TX	

4660 165TH AVE, MARATHON

Deed: GLOVER KALE DAVID

Map Area: LEE-AG

Checks/Tags:

Contract:

Route: 903-002-180

Lister/Date: JH, 10/07/2008

CID#: 0912775

Tax Dist: SR-R LEE

Review/Date: DS, 10/28/2008

DBA:

Plat Page: -

Entry Status: Inspected

MLS:

Subdiv: [NONE]

RURAL/AG DWELLING

Legal: 27-93-36 S.R.-REMB. LEE LOT A IN NW SE

No Land Dimensions Entered

Sales				Building Permits				Values				
Date	\$ Amount	NUTC	Recording	Date	Number	Tag	\$ Amount	Reason				
08/26/2010	\$155,000	D26	102227									

Res. Structure		Finish				Plumbing		Addition		Garage	
Occ. Code	101	Ttl Rooms Above #	6	Bedrooms Above #	2	Full Bath	1	Addition	1 of 2	Garage	1 of 1
Occ. Descr.	Single-Family / Owner Occupied	Ttl Rooms Below #	0	Bedrooms Below #	0	Shower Stall Bath		Year Built	1900	Style	Det Frm
Year Built	1908	Bsmt Fin Area #1				Toilet Room	1	EFA	59	W X L	0' X 0'
EFA / EFYr	101 / 1908	Bsmt Fin Area #2				Lavatory		EFA Year	1950	Area (SF)	864
Arch. Dsgn	N/A	Bsmt Fin Area #3				Water Closet		Style	1 Sty Frm	Year Built	1988
Style	2 Story Frame	Foundation	Conc / C Blk			Sink		Area (SF)	720	EFA	21
AreaSF/TLA	612 / 2,424	Exterior Walls	Wd Lap			Shower Stall/Tub		Condition	Above Normal	EFF Year	1988
		Roof	Asph / Gable			Mtl St Sh Bath					
		Interior Finish	Plas / Drwl			Mtl Stall Shower		Bsmt (SF)		Condition	NML
		Flooring	Carp / Vinyl			No Bathroom		NoBsmt Flr(SF)		Bsmt (SF)	
		Non-base Heating		Fireplace		Wet Bar		Heat	FHA - Gas	Qtrs Over	None
		Floor/Wall #	0	Prefab, 1 Sty	1	Whirlpool Bathroom		AC	Yes	Qtrs Over (SF)	
		Pipeless #	0			Whirlpool Tub		Attic (SF)		Qtrs AC (SF)	
		Hand Fired (Y/N)	No			No Hot Water Tank		See other pages for more additions.			
		Space Heat #	0			No Plumbing					
Condition	A NML	Appliances				No Sewer & Water Only				Door Opnrs	
Basement	1/2	Range Unit	Built-In Vacuums			Sewer & Water Only				Bsmt Stalls	
No Bsmt Flr.	0	Oven - Single	Intercom System			Water Only w/Sink					
Heat	FHA - Gas	Oven - Double	BI Stereo			Hot Tub					
AC	Yes	Dishwasher				Bidet					
Attic	None	Microwave				Fbgl Service Sink					
		Trash Compactor				Urinal					
		Jennair				Sauna					
		Security System				W'Pool Bath w/Shower					
						Water Only					
						No Tub/Shower					



Bldg / Addn	Description	Units	Year					
1 of 1	101 — Single-Family / Owner Occupied							
	2 Story Frame	612						
	Adjustment for basement - 1/2							
	Base Heat: FHA - Gas							
	Add Central Air	612						
#1	Porch: 1S Frame Enclosed	112 SF						
	Deck #1: Wood Deck-Low	86 SF						
	Deck #2: Concrete Patio-Low	384 SF						
	Veneer #1 1/2 Story Brick	16.0 LF						
	Plumbing	2						
#1	Fireplace: Prefab, 1 Story	1						
1 of 2 Adtn	1 Story Frame	720 SF	1900					
2 of 2 Adtn	1 Story Frame	480 SF	1900					
	Garage: Det Frame 0' X 0'	864 SF	1988					

	Count	Ag Building Description	Units		Year							
1 of 11 P:1	1	MTL POLE 925-Steel Utility Bldg	36' X 60'	2,160 SF	1974							
2 of 11 P:2	1	MACH FR @ .90 927-Shed	14' X 20'	280 SF	1900							
3 of 11 P:3	1	SHEDS FR @ .40 16X20&16X30 908-Lean-To	0' X 0'	800 SF	1900							
4 of 11 P:4	1	CONC 936-Silage Trench/Bunker	0' X 0'	25 LF	1969							
5 of 11 P:5	1	STORAGE 904-Bin - Stl. Grain Storage	18' X 16'	3,468 Bu	1981							
6 of 11 P:6	1	STORAGE 904-Bin - Stl. Grain Storage	30' X 16'	9,906 Bu	1981							
7 of 11 P:7	1	OP FR @ .90 927-Shed	24' X 48'	1,152 SF	1900							
8 of 11 P:9	1	GRANARY FR @ .70 927-Shed	10' X 18'	180 SF	1900							
9 of 11 P:10	1	HAY ROOF MTL P @ .20 927-Shed	16' X 48'	768 SF	1900							
10 of 11 P:11	1	HOG HSE FR @ .40 927-Shed	16' X 40'	640 SF	1900							
11 of 11 P:12	1	ELEV. OHB L FR @ .90 926-Crib	24' X 37'	888 SF	1900							

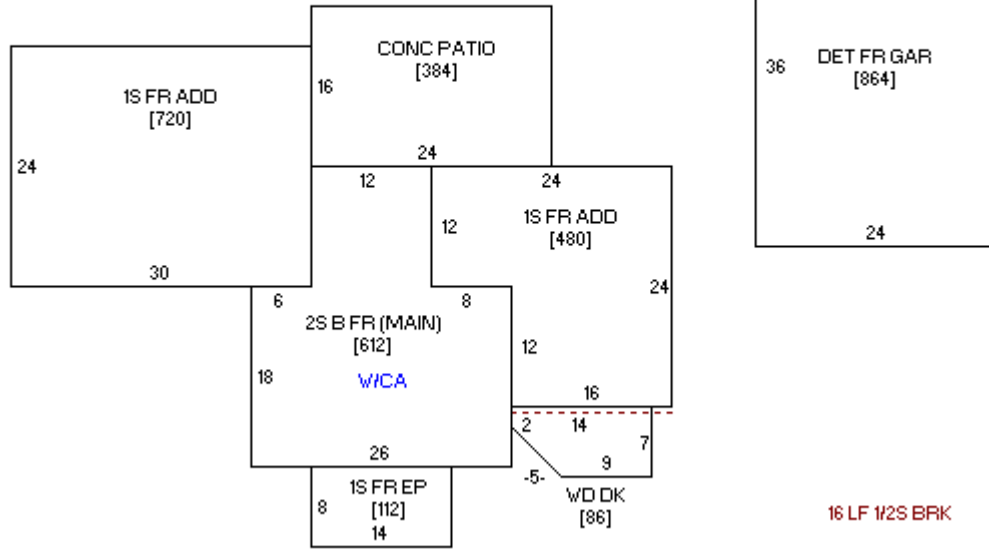

16 LF 1/2S BRK



10/09/2008