

13-24-200-004

#10735.00

R-Res



Pin: 13-24-200-004
Sale Date: 11/02/10
Sale Price: \$195,000
Acres: 10.05 Net
Classification: Rural Residential



LEGAL DESCRIPTION:

CLASS:

		-----	CSR'S	.00	
					CODE VALUE ACRES
GROSS	11.34		CURRENT		
ROADS			LAND	60,000	
D.D.			BLDG		
R.R.			DWLG	149,470(1)	
MISC					
			TOTAL	209,470	
NET	10.05				

24-90-38 R RESIDENTIAL
 ALTA MAPLE VALLEY
 NE NE
 PAR 11.34 A NE COR

		=====	=====	=====	=====
			YEAR	2010	
			LAND	60,000	
			BLDG		
			DWLG	149,470(1)	
			TOTAL	209,470	
			NET TX		

DEED HOLDER:	DATE REFER	CONTRACT HOLDER:	DATE REFER	YEAR	2009
KHAMPHAVONG JOHN	12102010 6			LAND	60,000
KHAMPHAVONG SOMYONG				BLDG	
812 FLINDT DR				DWLG	149,470(1)
STORM LAKE IA 50588				TOTAL	209,470
				NET TX	

HILL MARK EDWARD	03292004 5	..		YEAR	2008
HILL POM T				LAND	50,670
688 HWY 110				BLDG	
STORM LAKE IA 50588				DWLG	120,290(1)
				TOTAL	170,960

LILLIE CHARLES E	06072002 4	.		YEAR	2007
LILLIE BEVERLY ANN				LAND	50,670
688 HWY 110				BLDG	
STORM LAKE IA				DWLG	120,290(1)
				TOTAL	170,960

LILLIE CHARLES E	3	.		YEAR	2007
688 HWY 110				LAND	42,940
STORM LAKE IA				BLDG	
				DWLG	101,940(1)
				TOTAL	144,880

REMARKS:				YEAR	2007
3 W.D. #020241 06-11-89 (D022)				LAND	42,940
4 W.D. #021633 04-30-02				BLDG	
6 W.D.#103051-52 11-02-10 \$195,000				DWLG	101,940(1)
				TOTAL	144,880
				NET TX	

		-----	YEAR	2006	
			LAND	42,940	
			BLDG		
			DWLG	102,040(1)	
			TOTAL	144,980	
			NET TX		

688 HWY 110, STORM LAKE

Deed: **KHAMPHAVONG JOHN,KHAMPHAVONG SOMYON** Map Area: **MAPLE VALLEY-RES**
 Contract: Route: **916-001-600**
 CID#: **1073500** Tax Dist: **ALTA MAPLE VALLEY**
 DBA: Plat Page: -
 MLS: Subdiv: **[NONE]**

Checks/Tags:
 Lister/Date: **AP, 08/22/2008**
 Review/Date: **DS, 11/06/2008**
 Entry Status: **Estimated**

RURAL/RESIDENTIAL

Legal: 24-90-38 ALTA MAPLE VALLEY NE NE PAR 11.34 A NE COR

Land

Land Basis	Front	Rear	Side 1	Side 2	R. Lot	SF	Acres								
Site-Excess							1.000								
Excess 1							9.050								
Sub Total						437,778.00	10.050								
Grand Total						437,778.00	10.050								

Sales				Building Permits				Values				
Date	\$ Amount	NUTC	Recording	Date	Number	Tag	\$ Amount	Reason				
11/02/2010	\$195,000	D0	103051									
03/01/2004	\$85,000	D0	#040860									
04/30/2002	\$0	D17	#021633									
06/11/1989	\$0	D22	#020241									

Res. Structure		1 of 1		Finish				Plumbing				Addition				Garage	
Occ. Code	101	Ttl Rooms Above #	9	Bedrooms Above #	5	Full Bath	1	Addition	1 of 3	Garage	1 of 1						
Occ. Descr.	Single-Family / Owner Occupied	Ttl Rooms Below #	0	Bedrooms Below #	0	Shower Stall Bath	2	Year Built	1900	Style	Att Frm						
Year Built	1900	Bsmt Fin Area #1				Toilet Room		EFA	109	W X L	0' X 0'						
EFA / EfyR	109 / 1900	Bsmt Fin Area #2				Lavatory	2	EFA Year	1900	Area (SF)	720						
Arch. Dsgn	N/A	Bsmt Fin Area #3				Water Closet	1	Style	1 Sty Frm	Year Built	1960						
Style	2 Story Frame	Foundation	C Blk			Sink	1	Area (SF)	336	EFA	49						
AreaSF/TLA	1,104 / 3,280	Exterior Walls	Vinyl			Shower Stall/Tub		Condition	Very Good	EFF Year	1960						
Condition	V Good	Roof	Asph / Gable			Mtl St Sh Bath											
Basement	1/2	Interior Finish	Drwl			Mtl Stall Shower		Bsmt (SF)		Condition	V Good						
No Bsmt Flr.	0	Flooring	Carp / Vinyl			No Bathroom		NoBsmt Flr(SF)		Bsmt (SF)							
Heat	Yes	Non-base Heating		Fireplace		Wet Bar		Heat	Yes	Qtrs Over	None						
AC	Yes	Floor/Wall #	0			Whirlpool Bathroom		AC	Yes	Qtrs Over (SF)							
Attic	None	Pipeless #	0			Whirlpool Tub		Attic (SF)		Qtrs AC (SF)							
		Hand Fired (Y/N)	No			No Hot Water Tank		See other pages for more additions.									
		Space Heat #	0			No Plumbing											
		Appliances				Sewer & Water Only											
		Range Unit			Built-In Vacuums	Water Only w/Sink											
		Oven - Single			Intercom System	Hot Tub											
		Oven - Double			Bl Stereo	Bidet											
		Dishwasher				Fbgls Service Sink											
		Trash Compactor				Urinal											
		Jennair				Sauna											
		Security System				W'Pool Bath w/Shower											
						Water Only											
						No Tub/Shower											



Bldg / Addn	Description	Units	Year					
1 of 1	101 — Single-Family / Owner Occupied							
	2 Story Frame	1,104						
	Adjustment for basement - 1/2							
	Base Heat							
	Add Central Air	1,104						
	Deck #1: Wood Deck-Med	568 SF						
	Deck #2: Wood Deck-Med	100 SF						
	Plumbing	7						
	Garage: Att Frame	720 SF	1960					
1 of 3 Adtn	1 Story Frame	336 SF	1900					
2 of 3 Adtn	1 Story Frame	230 SF	1900					
3 of 3 Adtn	1 Story Frame	506 SF	1900					

Count	Ag Building Description	Units	Year
1 of 1 P:1	DBL FR @ .70 926-Crib	26' X 56' 1,456 SF	1900

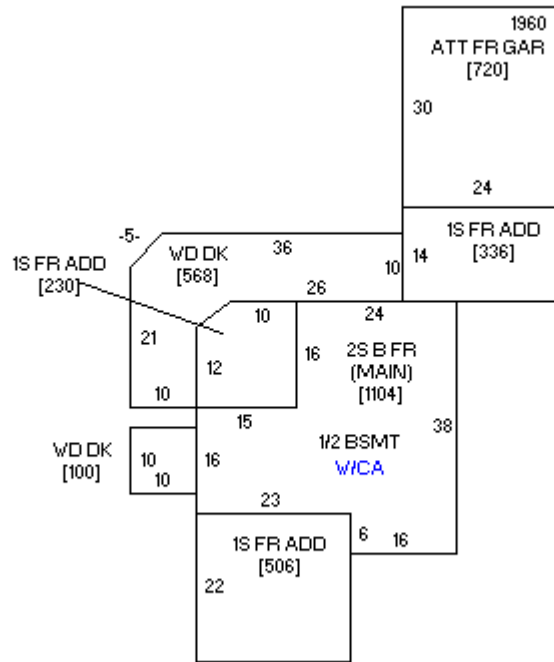

08/25/2008



01/19/2006