

Pin: 09-17-400-007
Sale Date: 05/26/10
Sale Price: \$82,000
Acres: 2.61 Net
Classification: Change in use

09-17-400-007

#10937.25



#3
MACH
SHED
18 X 52



LEGAL DESCRIPTION:

CLASS:

17-91-38
ALTA NOKOMIS
PARCEL B IN SW SE

A AGRICULTURE

		CSR'S	199.00		
				CODE	VALUE ACRES
GROSS	2.85	CURRENT			
ROADS	.24	LAND	3,490		
D.D.		BLDG	1,880(3)		
R.R.		DWLG	40,360(1)		
MISC					
		TOTAL	45,730		
NET	2.61				

		YEAR	2010 REFER: 1		
		LAND	3,490		
		BLDG	1,880(3)		
		DWLG	40,360(1)		
		TOTAL	45,730		
		NET TX			

DEED HOLDER:

DATE REFER

CONTRACT HOLDER:

DATE REFER

YEAR 2009 REFER: 2

FASSLER NICKOLAS
WILLER ERICA
261 570TH ST
ALTA IA 51002

06222010 3

LAND	3,490
BLDG	1,880(3)
DWLG	40,360(1)
TOTAL	45,730
NET TX	

MAGNUSSEN PAUL D
MAGNUSSEN JENNY L
261 570TH ST
ALTA IA 51002

YEAR	
LAND	
BLDG	
DWLG	
TOTAL	
NET TX	

REMARKS:

- 1 2010)SPLIT FROM -004 (06/22/10)
- 2 2009)SPLIT FROM -004 (06/22/10)
- 3 WD #101367 05/26/10 \$82,000 (D26)

YEAR	
LAND	
BLDG	
DWLG	
TOTAL	
NET TX	

YEAR	
LAND	
BLDG	
DWLG	
TOTAL	
NET TX	

261 570TH ST, ALTA

Deed: FASSLER NICKOLAS,WILLER ERICA

Map Area: NOKOMIS-AG

Checks/Tags:

Contract:

Route: 909-001-580

Lister/Date: MA, 07/30/2008

CID#: 1093725

Tax Dist: ALTA NOKOMIS

Review/Date: DS, 11/05/2008

DBA:

Plat Page:

Entry Status: Estimated

MLS: 14435

Subdiv: [NONE]

RURAL/AG DWELLING

Legal: 17-91-38 ALTA NOKOMIS PARCEL B IN SW SE

No Land Dimensions Entered

Sales			Building Permits				Values				
Date	\$ Amount	NUTC	Recording	Date	Number	Tag	\$ Amount	Reason			
05/26/2010	\$82,000	D26	101367								

Res. Structure		Finish				Plumbing		Addition		Garage	
Occ. Code	101	Ttl Rooms Above #	9	Bedrooms Above #	5	Full Bath	1	Addition	1 of 1	Garage	No garages
Occ. Descr.	Single-Family / Owner Occupied	Ttl Rooms Below #	0	Bedrooms Below #	0	Shower Stall Bath		Year Built	1880	Style	
Year Built	1880	Bsmt Fin Area #1				Toilet Room		EFA	129	W X L	
EFA / EFYr	129 / 1880	Bsmt Fin Area #2				Lavatory		EFA Year	1880	Area (SF)	
Arch. Dsgn	N/A	Bsmt Fin Area #3				Water Closet		Style	1 Sty Frm	Year Built	
Style	1 1/2 Story Frame	Foundation	Stn			Sink		Area (SF)	224	EFA	
AreaSF/TLA	868 / 1,700	Exterior Walls	Wd Lap			Shower Stall/Tub		Condition	Below Normal	EFF Year	
		Roof	Asph / Gable			Mtl St Sh Bath					
		Interior Finish	Plas / Panel			Mtl Stall Shower		Bsmt (SF)		Condition	
		Flooring	Carp / Vinyl			No Bathroom		NoBsmt Flr(SF)		Bsmt (SF)	
		Non-base Heating		Fireplace		Wet Bar		Heat	FHA - Gas	Qtrs Over	
		Floor/Wall #	0			Whirlpool Bathroom		AC	No	Qtrs Over (SF)	
		Pipeless #	0			Whirlpool Tub		Attic (SF)		Qtrs AC (SF)	
		Hand Fired (Y/N)	No			No Hot Water Tank					
Condition	BL NML	Space Heat #	0			No Plumbing				Door Opnrs	
		Appliances				Sewer & Water Only				Bsmt Stalls	
Basement	1/2	Range Unit		Built-In Vacuums		Water Only w/Sink					
No Bsmt Flr.	0	Oven - Single		Intercom System		Hot Tub					
Heat	FHA - Gas	Oven - Double		BI Stereo		Bidet					
AC	No	Dishwasher				Fbgl Service Sink					
Attic	None	Microwave				Urinal					
		Trash Compactor				Sauna					
		Jennair				W'Pool Bath w/Shower					
		Security System				Water Only					
						No Tub/Shower					



Bldg / Addn	Description	Units	Year						
1 of 1	101 — Single-Family / Owner Occupied								
	1 1/2 Story Frame	868							
	Adjustment for basement - 1/2								
	Base Heat: FHA - Gas								
#1	Porch: 1S Frame Enclosed	160 SF							
#2	Porch: 1S Frame Enclosed	136 SF							
#3	Porch: 1S Frame Enclosed	30 SF							
1 of 1 Adtn	1 Story Frame	224 SF		1880					

	Count	Ag Building Description	Units		Year						
1 of 3 P:3	1	MTL P FR 925-Steel Utility Bldg	18' X 52'	936 SF	1982						
2 of 3 P:5	1	MACH FR @ .40 927-Shed	48' X 48'	2,304 SF	1900						
3 of 3 P:6	1	MACH MTL POLE @ .90 927-Shed	28' X 60'	1,680 SF	1900						

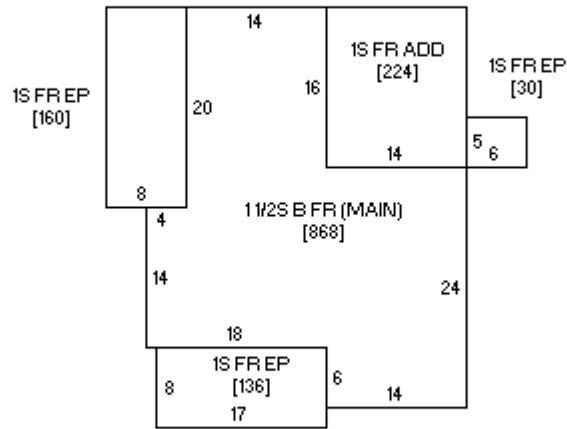



09/18/2008