

Pin: 10-29-200-006
Sale Date: 12/09/10
Sale Price: \$100,000
Acres: 6.54 Net
Classification: Change in use from
Ag to Rural Residential

10-29-200-006

#9754.75

R-Res



LEGAL DESCRIPTION:

CLASS:

29-91-37
ALTA WASHINGTON
LOT A IN NE NE

A AGRICULTURE

-----		CSR'S	481.00	-----	
				CODE	VALUE ACRES
GROSS	7.00	CURRENT			
ROADS	.46	LAND	8,440		
D.D.		BLDG	9,400(4)		
R.R.		DWLG	71,660(1)		
MISC					
		TOTAL	89,500		
NET	6.54				

=====		=====	=====	=====	
		YEAR	2011	REFER:	1
		LAND	8,440		
		BLDG	9,400(4)		
		DWLG	71,660(1)		
		TOTAL	89,500		
		NET TX			

-----		-----	-----	-----	-----	-----
DEED HOLDER:	DATE REFER	CONTRACT HOLDER:	DATE REFER	YEAR	2010	REFER: 2
MERTEN WILLIAM H LIVING TRUST	12272010 3			LAND	8,440	
				BLDG	9,400(4)	
				DWLG	71,660(1)	
				TOTAL	89,500	
				NET TX		

BRUNS ORIN L				YEAR		
				LAND		
				BLDG		
				DWLG		
				TOTAL		
				NET TX		

520 OTSEGO #224				YEAR		
				LAND		
				BLDG		
				DWLG		
				TOTAL		
				NET TX		

				YEAR		
				LAND		
				BLDG		
				DWLG		
				TOTAL		
				NET TX		

				YEAR		
				LAND		
				BLDG		
				DWLG		
				TOTAL		
				NET TX		

REMARKS:

1 !2011)SPLIT FROM -002 (12/27/10)

2 !2010)SPLIT FROM -002 (12/27/10)

3 WD #103392 12/09/10 \$100,000 (D26)

				YEAR		
				LAND		
				BLDG		
				DWLG		
				TOTAL		
				NET TX		

5821 90TH AVE, STORM LAKE

Deed: **MERTEN WILLIAM H,LIVING TRUST**

Map Area: **WASH-RES**

Checks/Tags:

Contract:

Route: **910-002-210**

Lister/Date: **LF, 08/04/2008**

CID#: **0975475**

Tax Dist: **ALTA WASHINGTON**

Review/Date: **DS, 12/08/2008**

DBA:

Plat Page: -

Entry Status: **Inspected**

MLS:

Subdiv: **[NONE]**

RURAL/RESIDENTIAL

Legal:29-91-37 ALTA WASHINGTON LOT A IN NE NE

Land

Land Basis	Front	Rear	Side 1	Side 2	R. Lot	SF	Acres								
Site-Excess							1.000								
Excess 1							5.540								
Sub Total						284,882.40	6.540								
Grand Total						284,882.40	6.540								

Sales				Building Permits				Values					
Date	\$ Amount	NUTC	Recording	Date	Number	Tag	\$ Amount	Reason					
12/09/2010	\$100,000	D26	103392										

Res. Structure		Finish				Plumbing				Addition				Garage									
Occ. Code	101	Ttl Rooms Above #	4	Bedrooms Above #	2	Full Bath	1	Addition	1 of 1	Garage	1 of 1	Occ. Descr.	Single-Family / Owner Occupied	Ttl Rooms Below #	1	Bedrooms Below #	0	Shower Stall Bath	Year Built	1968	Style	Det Frm	
Year Built	1941	Bsmt Fin Area #1	225	Table		Toilet Room		EFA	41	W X L	0' X 0'	Year Built	1941	Bsmt Fin Area #2			Lavatory	EFA Year	1968	Area (SF)	576	Arch. Dsgn	N/A
EFA / EFYr	68 / 1941	Bsmt Fin Area #3				Water Closet	1	Style	1 Sty Frm	Year Built	1940	Style	1 Story Frame	Foundation	C Blk		Sink	Area (SF)	256	EFA	69	Style	
Arch. Dsgn		Foundation	C Blk			Shower Stall/Tub		Condition	Above Normal	EFF Year	1940	Interior Finish	Plas / Panel	Exterior Walls	Stl		Mtl St Sh Bath			Condition	NML	Condition	
Style		Roof	Asph / Gable			Mtl Stall Shower		Bsmt (SF)	256	Condition		Flooring	Carp / Vinyl	Roof	Asph / Gable		No Bathroom	Bsmt (SF)		Condition	NML	Condition	
AreaSF/TLA	780 / 1,309	Non-base Heating	Fireplace			Wet Bar		NoBsmt Flr(SF)		Condition		Heat	FHA - Gas	Interior Finish	Plas / Panel		No Plumbing	Attic (SF)		Condition		Condition	
Condition	A NML	Floor/Wall #	0			Whirlpool Bathroom		Heat	FHA - Gas	Qtrs Over	None	Space Heat #	0	Hand Fired (Y/N)	No		Whirlpool Tub	AC	Yes	Qtrs Over (SF)		Qtrs Over (SF)	
Basement	Full	Pipeless #	0			No Hot Water Tank		AC	Yes	Qtrs AC (SF)		Appliances		Hand Fired (Y/N)	No		No Plumbing			Qtrs AC (SF)		Qtrs AC (SF)	
No Bsmt Flr.	0	Hand Fired (Y/N)	No			Sewer & Water Only		Attic (SF)		Door Opnrs		Range Unit	Built-In Vacuums	Space Heat #	0		Water Only w/Sink			Door Opnrs		Door Opnrs	
Heat	FHA - Gas	Space Heat #	0			Water Only w/Sink				Bsmt Stalls		Oven - Single	Intercom System				Hot Tub			Bsmt Stalls		Bsmt Stalls	
AC	Yes					Hot Tub						Oven - Double	BI Stereo				Bidet						
Attic	1/2 Finished, 273SF					Water Only						Dishwasher					Fbgls Service Sink						
						Water Only						Trash Compactor					Urinal						
						Water Only						Jennair					Sauna						
						No Tub/Shower						Security System					W'Pool Bath w/Shower						



Bldg / Addn	Description	Units	Year					
1 of 1	101 — Single-Family / Owner Occupied							
	1 Story Frame	780						
#1	Bsmt Fin - Rec. Room (Single) (Low)	225 Tbl						
	Base Heat: FHA - Gas							
	Add Central Air	780						
	Add 1/2 Finished attic	273						
#1	Porch: 1S Frame Enclosed	48 SF						
	Deck #1: Fbgl/Mtl Roof-Low	160 SF						
	Deck #2: Concrete Patio-Low	160 SF						
	Plumbing	3						
1 of 1 Adtn	1 Story Frame	256 SF	1968					
	Garage: Det Frame 0' X 0'	576 SF	1940					

	Count	Ag Building Description	Units		Year						
1 of 4 P:2	1	L FR @ .40 906-Barn - Flat	38' X 48'	1,824 SF	1900						
2 of 4 P:3	1	SHED FR @ .20 908-Lean-To	32' X 38'	1,216 SF	1900						
3 of 4 P:4	1	DRYER 904-Bin - Stl. Grain Storage	36' X 24'	21,594 Bu	1979						
4 of 4 P:5	1	MTL STL 925-Steel Utility Bldg	40' X 100'	4,000 SF	1974						

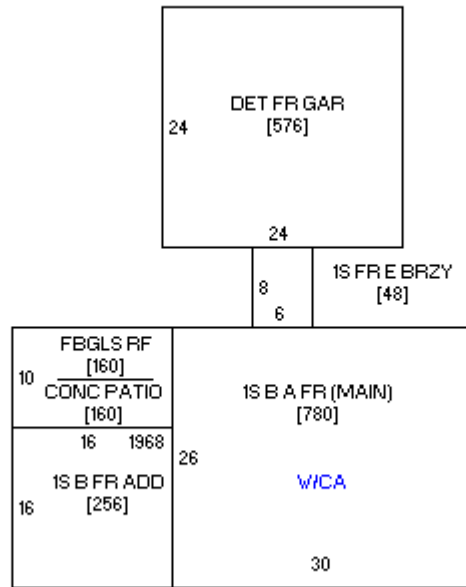



08/11/2008