

Pin: 02-32-200-006
Sale Date: 07/14/11
Sale Price: \$57,000
Acres: 7.34 Net
Classification: Split - Change in
Use from Ag to Rural Residential

02-32-200-006

#10571.50

R-Res



LEGAL DESCRIPTION:

CLASS:

32-93-37
SIOUX VALLEY BARNES
LOT C IN NE NE

A AGRICULTURE

		CSR'S	578.00		
				CODE	VALUE ACRES
GROSS	7.94	CURRENT			
ROADS	.60	LAND	12,830		
D.D.		BLDG	3,190(10)		
R.R.		DWLG	32,210(1)		
MISC					
		TOTAL	48,230		
NET	7.34				

		YEAR	2011 REFER: 1		
		LAND	12,830		
		BLDG	3,190(10)		
		DWLG	32,210(1)		
		TOTAL	48,230		
		NET TX			

DEED HOLDER:	DATE REFER	CONTRACT HOLDER:	DATE REFER	YEAR	
FRIEDRICH MATTHEW	08182011 2			LAND	
FRIEDRICH ANGELA				BLDG	
4727 90TH AVE				DWLG	
LINN GROVE IA 51033				TOTAL	
				NET TX	
KACMARYNSKI NORBERT				YEAR	
				LAND	
				BLDG	
				DWLG	
				TOTAL	
				NET TX	
				YEAR	
				LAND	
				BLDG	
				DWLG	
				TOTAL	
				NET TX	

REMARKS:	YEAR	
1 !2011)SPLIT FROM -002 (08/18/11)	LAND	
2 COD #111879 07/14/11 \$57,000 (D26)	BLDG	
	DWLG	
	TOTAL	
	NET TX	
	YEAR	
	LAND	
	BLDG	
	DWLG	
	TOTAL	
	NET TX	

Res. Structure		Finish				Plumbing		Addition		Garage	
Occ. Code	101	Ttl Rooms Above #	8	Bedrooms Above #	4	Full Bath	2	Addition	1 of 5	Garage	No garages
Occ. Descr.	Single-Family / Owner Occupied	Ttl Rooms Below #	0	Bedrooms Below #	0	Shower Stall Bath		Year Built	1920	Style	
Year Built	1920	Bsmt Fin Area #1				Toilet Room		EFA	89	W X L	
EFA / EFYr	89 / 1920	Bsmt Fin Area #2				Lavatory		EFA Year	1920	Area (SF)	
Arch. Dsgn	N/A	Bsmt Fin Area #3				Water Closet		Style	1 Sty Frm	Year Built	
Style	2 Story Frame	Foundation	C Blk			Sink		Area (SF)	156	EFA	
AreaSF/TLA	728 / 2,440	Exterior Walls	Wd Lap / Vinyl			Shower Stall/Tub		Condition	Normal	EFF Year	
Condition	NML	Roof	Asph / Gable			Mtl St Sh Bath				Condition	
Basement	Full	Interior Finish	Plas / Drwl			Mtl Stall Shower		Bsmt (SF)			
No Bsmt Flr.	0	Flooring	Carp / Vinyl			No Bathroom		NoBsmt Flr(SF)		Bsmt (SF)	
Heat	FHA - Gas	Non-base Heating		Fireplace		Wet Bar		Heat	FHA - Gas	Qtrs Over	
AC	Yes	Floor/Wall #	0	Prefab, 1 Sty	1	Whirlpool Bathroom		AC	Yes	Qtrs Over (SF)	
Attic	None	Pipeless #	0			Whirlpool Tub		Attic (SF)		Qtrs AC (SF)	
		Hand Fired (Y/N)	No			No Hot Water Tank		See other pages for more additions.			
		Space Heat #	0			No Plumbing				Door Opnrs	
		Appliances				Sewer & Water Only				Bsmt Stalls	
		Range Unit	Built-In Vacuums			Water Only w/Sink					
		Oven - Single	Intercom System			Hot Tub					
		Oven - Double	BI Stereo			Bidet					
		Dishwasher				FbglS Service Sink					
		Microwave				Urinal					
		Trash Compactor				Sauna					
		Jennair				W'Pool Bath w/Shower					
		Security System				Water Only					
						No Tub/Shower					



Bldg / Addn	Description	Units	Year					
1 of 1	101 — Single-Family / Owner Occupied							
	2 Story Frame	728						
	Base Heat: FHA - Gas							
	Add Central Air	728						
#1	Porch: 1S Frame Enclosed	176 SF						
#2	Porch: 1S Frame Screen	168 SF						
	Deck #1: Wood Deck-Med	180 SF						
	Plumbing	2						
#1	Fireplace: Prefab, 1 Story	1						
1 of 5 Adtn	1 Story Frame	156 SF	1920					
2 of 5 Adtn	2 Story Frame	96 SF	1920					
3 of 5 Adtn	1 Story Frame	24 SF	1999					
4 of 5 Adtn	1 Story Frame	576 SF	1960					
5 of 5 Adtn	1 Story Frame	36 SF	1920					

Count	Ag Building Description	Units	Year
1 of 5 P:1	GARAGE FR 924-Machine or Utility Bldg	10' X 20' 200 SF	1970
2 of 5 P:2	CB FR @ .90 906-Barn - Flat	32' X 48' 1,536 SF	1900
3 of 5 P:4	DBL OHB FR @ .70 926-Crib	25' X 40' 1,000 SF	1900
4 of 5 P:7	TOOL FR @ .40 927-Shed	8' X 12' 96 SF	1900
5 of 5 P:8	MTL POLE MACH SHED 925-Steel Utility Bldg	48' X 30' 1,440 SF	2001

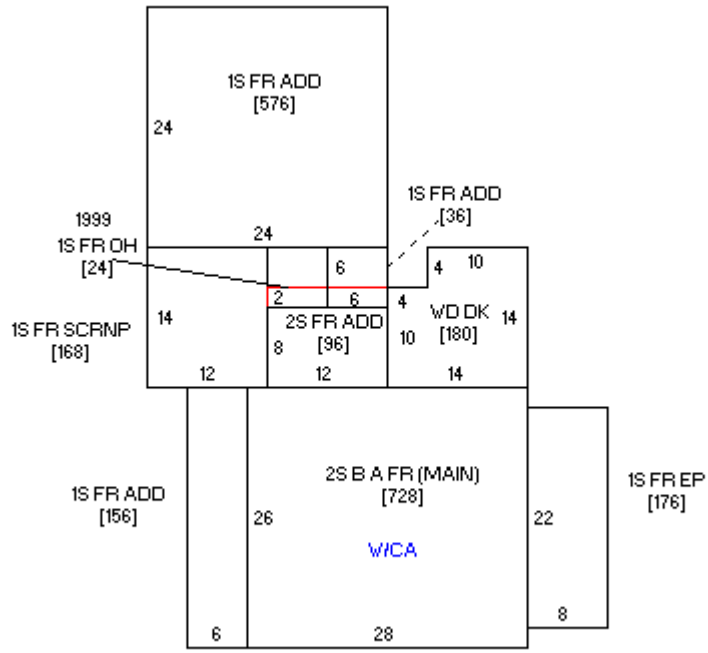



09/11/2008