

LEGAL DESCRIPTION:

CLASS:

25-90-35 R RESIDENTIAL  
NEWELL PROV. NEWELL  
LOT G IN SE SW

-----		CSR'S	.00		
				CODE	VALUE ACRES
GROSS	3.52	CURRENT			
ROADS	.28	LAND	21,000		
D.D.		BLDG			
R.R.		DWLG	40,180( 1)		
MISC					
		TOTAL	61,180		
NET	3.24				
-----		-----		-----	

YEAR		2011			
LAND	21,000	ROAD		.28	
BLDG					
DWLG	40,180( 1)				
TOTAL	61,180				
NET TX					

-----		-----		-----		-----	
DEED HOLDER:	DATE REFER	CONTRACT HOLDER:	DATE REFER	YEAR	2010		
BURKHART RYAN L	11182011 5			LAND	21,000	ROAD	.28
				BLDG			
2431 650TH ST				DWLG	40,180( 1)		
NEWELL IA 50568				TOTAL	61,180		
				NET TX			

-----		-----		-----		-----	
HANSON TIM	06242011 4	..		YEAR	2009		
PUHRMANN ERIN				LAND	21,000	ROAD	.28
3280 180TH ST				BLDG			
SAC CITY IA 50583				DWLG	40,180( 1)		
				TOTAL	61,180		

-----		-----		-----		-----	
HANSON TIM	01062011	OGDEN RODNEY	3	NET TX			
PUHRMANN ERIN		OGDEN CHRISTINE		-----		-----	
3280 180TH ST		2431 650TH ST		YEAR	2008		
SAC CITY IA 50583		NEWELL IA 50568		LAND	11,970	ROAD	.28

-----		-----		-----		-----	
HANSON TIM	2			BLDG			
PUHRMANN ERIN				DWLG	28,410( 1)		
2431 650TH ST				TOTAL	40,380		
NEWELL IA 50568				NET TX			

-----		-----		-----		-----	
REMARKS:				YEAR	2007 REFER: 1		
1 07)SPLIT FROM -005 (11/20/07)				LAND	2,630		
2 WD #072242 07/18/07 \$39,900 (D026)				BLDG	1,900( 9)		
3 CONT #103419 11-10-10 \$60,000				DWLG	25,420( 1)		
4 FORFEITURE #111349 05-23-11				TOTAL	29,950		
5 W.D. #112720 09-28-11 \$66,000				NET TX			
				-----		-----	
				YEAR			
				LAND			
				BLDG			
				DWLG			
				TOTAL			
				NET TX			
-----		-----		-----		-----	



Res. Structure		Finish				Plumbing		Addition		Garage	
Occ. Code	101	Ttl Rooms Above #	6	Bedrooms Above #	3	Full Bath	1	Addition	1 of 3	Garage	1 of 1
Occ. Descr.	Single-Family / Owner Occupied	Ttl Rooms Below #	0	Bedrooms Below #	0	Shower Stall Bath	1	Year Built	1890	Style	Det Frm
Year Built	1890	Bsmt Fin Area #1				Toilet Room		EFA	119	W X L	0' X 0'
EFA / EFYr	119 / 1890	Bsmt Fin Area #2				Lavatory		EFA Year	1890	Area (SF)	720
Arch. Dsgn	N/A	Bsmt Fin Area #3				Water Closet		Style	1 Sty Frm	Year Built	2011
Style	1 1/2 Story Frame	Foundation	C Blk / Strn			Sink		Area (SF)	48	EFA	1
AreaSF/TLA	560 / 1,304	Exterior Walls	Stl			Shower Stall/Tub		Condition	Normal	EFF Year	2011
Condition	NML	Roof	Asph / Gable			Mtl St Sh Bath					
Basement	1/2	Interior Finish	Plas / Drwl / Panel			Mtl Stall Shower		Bsmt (SF)		Condition	NML
No Bsmt Flr.	0	Flooring	Carp / Vinyl / Hdwd			No Bathroom		NoBsmt Flr(SF)		Bsmt (SF)	
Heat	FHA - Gas	<b>Non-base Heating</b>		<b>Fireplace</b>		Wet Bar		Heat	FHA - Gas	Qtrs Over	None
AC	Yes	Floor/Wall #	0			Whirlpool Bathroom		AC	Yes	Qtrs Over (SF)	
Attic	None	Pipeless #	0			Whirlpool Tub		Attic (SF)		Qtrs AC (SF)	
		Hand Fired (Y/N)	No			No Hot Water Tank		See other pages for more additions.			
		Space Heat #	0			No Plumbing				Door Opnrs	
		<b>Appliances</b>				Sewer & Water Only				Bsmt Stalls	
		Range Unit	Built-In Vacuums			Water Only w/Sink					
		Oven - Single	Intercom System			Hot Tub					
		Oven - Double	BI Stereo			Bidet					
		Dishwasher				FbglS Service Sink					
		Microwave				Urinal					
		Trash Compactor				Sauna					
		Jennair				W'Pool Bath w/Shower					
		Security System				Water Only					
						No Tub/Shower					



Bldg / Addn	Description	Units	Year
1 of 1	101 — Single-Family / Owner Occupied		
	1 1/2 Story Frame	560	
	Adjustment for basement - 1/2		
	Base Heat: FHA - Gas		
	Add Central Air	560	
#1	Porch: 1S Frame Enclosed	20 SF	
	Plumbing	2	
1 of 3 Adtn	1 Story Frame	48 SF	1890
2 of 3 Adtn	1 Story Frame	192 SF	1890
3 of 3 Adtn	1 Story Frame	112 SF	1890
	Garage: Det Frame 0' X 0'	720 SF	2011

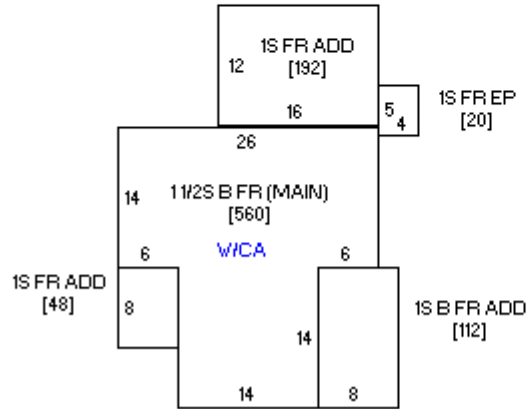
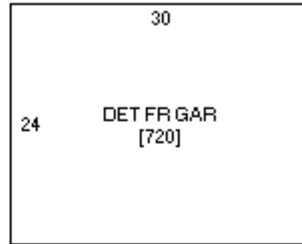



10/20/2011



09/16/2008



05/29/2007