

08-18-200-006

# 7804.10<sup>25</sup>

R-Res

Pin: 08-18-200-006

Sale Date: 11-16-12

Sale Price: \$115,000

Acres: 4.76 Net

Classification: Rural Residential



LEGAL DESCRIPTION:

CLASS:

18-92-35 R RESIDENTIAL  
A.C.T. FAIRFIELD  
IRR PT IN SE NE

-----		CSR'S	.00	-----	
				CODE	VALUE ACRES
GROSS	4.79	CURRENT			
ROADS	.03	LAND	20,000		
D.D.		BLDG			
R.R.		DWLG	100,790( 1)		
MISC					
		TOTAL	120,790		
NET	4.76				

=====		YEAR	2012	=====	
		LAND	20,000	ROAD	.03
		BLDG			
		DWLG	100,790( 1)		
		TOTAL	120,790		
		NET TX			

DEED HOLDER:	DATE REFER	CONTRACT HOLDER:	DATE REFER	YEAR	2011	-----	
MADSEN DANIEL J	12312012 1			LAND	20,000	ROAD	.03
MADSEN MICHELE SARA				BLDG			
1575 540TH ST				DWLG	51,340( 1)		
ALBERT CITY IA 50510				TOTAL	71,340		
				NET TX			

-----		YEAR	2010	-----	
KRAAI ROBERT	05032010 6	LAND	20,000	ROAD	.03
		BLDG			
1906 4TH AVE SE		DWLG	76,700( 1)		
SIOUX CENTER IA 51250		TOTAL	96,700		
		NET TX			

-----		YEAR	2009	-----	
FEDERAL NATIONAL MORTGAGE	11182009 5	LAND	20,000	ROAD	.03
		BLDG			
3900 WISCONSIN AVE		DWLG	76,700( 1)		
WASHINGTON DC 20016-9779		TOTAL	96,700		
		NET TX			

-----		YEAR	2008	-----	
REMARKS:		LAND	11,060	ROAD	.03
1 W.D. #123295 11-16-12 \$115,000		BLDG			
4 SHERIFF #093218 10-12-09 \$105,178.17		DWLG	53,080( 1)		
5 WD #093219 10-09-09 \$105,178.17		TOTAL	64,140		
6 W.D. #100795 04-01-10 \$41,500 (D000)		NET TX			

-----		YEAR	2007	-----	
		LAND	11,060	ROAD	.03
		BLDG			
		DWLG	53,080( 1)		
		TOTAL	64,140		
		NET TX			



5039 200TH AVE, ALBERT CITY

Deed: MADSEN DANIEL J,MADSEN MICHELE SARA

Map Area: FAIRFIELD-RES

Checks/Tags:

Contract:

Route: 905-001-520

Lister/Date: JF, 09/30/2008

CID#: 0780425

Tax Dist: ACT FAIRFIELD

Review/Date: DS, 10/23/2008

DBA:

Plat Page: -

Entry Status: Inspected

MLS: 15448

Subdiv: [NONE]

RURAL/RESIDENTIAL

Legal: 18-92-35 A.C.T. FAIRFIELD IRR PT IN SE NE

Land									
Land Basis	Front	Rear	Side 1	Side 2	R. Lot	SF	Acres		
Site-Excess							1.000		
Excess 1							3.760		
Sub Total						207,345.60	4.760		
Grand Total						207,345.60	4.760		

Sales				Building Permits				Values			
Date	\$ Amount	NUTC	Recording	Date	Number	Tag	\$ Amount	Reason			
11/16/2012	\$115,000	D0	123295	12/9/2010	OFFICE	Y	\$0	Ext-Remodel			
04/01/2010	\$41,500	D12	100795	12/9/2010	OFFICE	Y	\$0	Int-Remodel			
10/12/2009	\$105,178	D12	093218								
10/09/2009	\$105,178	D12	093219								

Res. Structure		1 of 1		Finish				Plumbing				Addition		Garage	
Occ. Code	101	Ttl Rooms Above #	7	Bedrooms Above #	4	Full Bath	1	Addition	1 of 1	Garage	1 of 1				
Occ. Descr.	Single-Family / Owner Occupied	Ttl Rooms Below #	0	Bedrooms Below #	0	Shower Stall Bath		Year Built	1900	Style	Det Frm				
Year Built	1900	Bsmt Fin Area #1				Toilet Room	1	EFA	109	W X L	0' X 0'				
EFA / EFYr	109 / 1900	Bsmt Fin Area #2				Lavatory	1	EFA Year	1900	Area (SF)	360				
Arch. Dsgn	N/A	Bsmt Fin Area #3				Water Closet		Style	1 Sty Frm	Year Built	1940				
Style	1 1/2 Story Frame	Foundation	C Blk			Sink		Area (SF)	188	EFA	69				
AreaSF/TLA	836 / 1,609	Exterior Walls	Wd Lap			Shower Stall/Tub		Condition	Excellent	EFF Year	1940				
GLA 1st/2nd	1,024 / 585	Roof	Asph / Gable			Mtl St Sh Bath									
Condition	EXCEL	Interior Finish	Plas			Mtl Stall Shower	1	Bsmt (SF)		Condition	V Good				
Basement	Full	Flooring	Carp / Vinyl			No Bathroom		NoBsmt Flr(SF)		Bsmt (SF)					
No Bsmt Flr.	0	Non-base Heating		Fireplace		Wet Bar		Heat	FHA - Gas	Qtrs Over	None				
Heat	FHA - Gas	Floor/Wall #	0			Whirlpool Bathroom		AC	Yes	Qtrs Over (SF)					
AC	Yes	Pipeless #	0			Whirlpool Tub		Attic (SF)		Qtrs AC (SF)					
Attic	None	Hand Fired (Y/N)	No			No Hot Water Tank				Door Opnrs					
		Space Heat #	0			No Plumbing				Bsmt Stalls					
		Appliances				Sewer & Water Only									
		Range Unit	Built-In Vacuums			Water Only w/Sink									
		Oven - Single	Intercom System			Hot Tub									
		Oven - Double	BI Stereo			Bidet									
		Dishwasher				Fbgls Service Sink									
		Microwave				Urinal									
		Trash Compactor				Sauna									
		Jennair				W'Pool Bath w/Shower	1								
		Security System				Water Only									
						No Tub/Shower									



Bldg / Addn 1 of 1	Description	Units	Year				
	101 — Single-Family / Owner Occupied						
	1 1/2 Story Frame	836					
	Base Heat: FHA - Gas						
	Add Central Air	836					
#1	Porch: 1S Frame Open	84 SF					
	Deck #1: Wood Deck-Med	208 SF					
	Deck #2: Wood Deck-Med	508 SF					
	Plumbing	5					
1 of 1	Adtn 1 Story Frame	188 SF	1900				
	Garage: Det Frame 0' X 0'	360 SF	1940				

	Count	Ag Building Description	Units	Year
1 of 2 P:1	1	MTL POLE 925-Steel Utility Bldg	54' X 72' 3,888 SF	1987
2 of 2 P:6	1	GRANARY @.90 908-Lean-To	8' X 28' 224 SF	1976

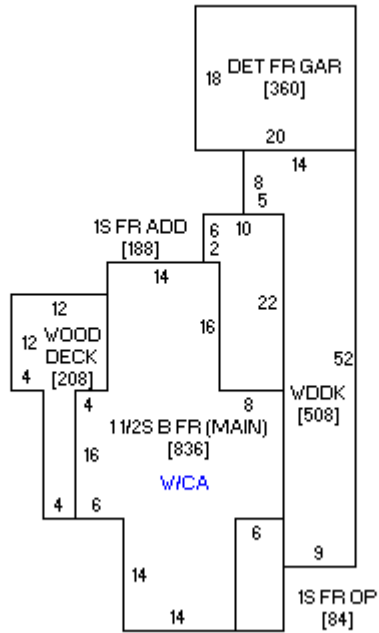



11/09/2011