

Pin: 02-16-200-006
Sale Date: 12/17/13
Sale Price: \$141,428
Acres: 10.62 Net
Classification: Agriculture

02-16-200-006

#10404.50

AG



10

LEGAL DESCRIPTION:

CLASS:

16-93-37
SIOUX VALLEY BARNES
PARC A IN NE NE

A AGRICULTURE

| | | CSR'S | 802.32 | | |
|-------|-------|---------|------------|------|-------------|
| | | | | CODE | VALUE ACRES |
| GROSS | 12.54 | CURRENT | | | |
| ROADS | 1.92 | LAND | 26,080 | | |
| D.D. | | BLDG | 6,870(10) | | |
| R.R. | | DWLG | 36,860(1) | | |
| MISC | | | | | |
| | | TOTAL | 69,810 | | |
| NET | 10.62 | | | | |

| | | YEAR | 2014 REFER: 1 | | |
|--|--|--------|---------------|--|--|
| | | LAND | 26,080 | | |
| | | BLDG | 6,870(10) | | |
| | | DWLG | 36,860(1) | | |
| | | TOTAL | 69,810 | | |
| | | NET TX | | | |

DEED HOLDER:

DATE REFER

CONTRACT HOLDER:

DATE REFER

YEAR 2013 REFER: 2

TUNUNK KRISTIAN

01272014 3

708 480TH ST
LINN GROVE IA 51033

| | |
|--------|------------|
| LAND | 26,080 |
| BLDG | 6,870(10) |
| DWLG | 36,860(1) |
| TOTAL | 69,810 |
| NET TX | |

TAYLOR GLEN A REVOCABLE TRUST

| | |
|--------|--|
| YEAR | |
| LAND | |
| BLDG | |
| DWLG | |
| TOTAL | |
| NET TX | |

REMARKS:

- 1 !2014)SPLIT FROM -002 (01/27/14)
- 2 !2013)SPLIT FROM -002 (01/27/14)
- 3 TWD #133931 12/17/13 \$141,428 (D26)

| | |
|--------|--|
| YEAR | |
| LAND | |
| BLDG | |
| DWLG | |
| TOTAL | |
| NET TX | |

986 440TH ST, LINN GROVE

Deed: TUNUNK KRISTIAN

Map Area: BARNES-AG

Checks/Tags:

Contract:

Route: 902-001-430

Lister/Date: CL, 07/02/2008

CID#: 1040450

Tax Dist: SV BARNES

Review/Date: DS, 10/16/2008

DBA:

Plat Page:

Entry Status: Inspected

MLS:

Subdiv: [NONE]

RURAL/AG DWELLING

Legal: 16-93-37 SIOUX VALLEY BARNES PARC A IN NE NE

| Land | | | | | | | | | | |
|-------------|-------|------|--------|--------|--------|------------|--------|--|--|--|
| Land Basis | Front | Rear | Side 1 | Side 2 | R. Lot | SF | Acres | | | |
| Ag Land | | | | | | 462,607.20 | 10.620 | | | |
| Grand Total | | | | | | 462,607.20 | 10.620 | | | |

| Sales | | | | Building Permits | | | | Values | | | |
|------------|-----------|------|-----------|------------------|--------|-----|-----------|-------------|--|--|--|
| Date | \$ Amount | NUTC | Recording | Date | Number | Tag | \$ Amount | Reason | | | |
| 12/17/2013 | \$141,528 | D26 | 133931 | 7/2/2008 | | N | \$0 | Int-Remodel | | | |

| Res. Structure 1 of 1 | | Finish | | | | Plumbing | | Addition | | Garage | |
|-----------------------|-----------------------------------|-------------------------|--------------------|------------------|---|----------------------|---|-------------------------------------|--------------|----------------|------------|
| Occ. Code | 101 | Ttl Rooms Above # | 8 | Bedrooms Above # | 5 | Full Bath | 1 | Addition | 1 of 2 | Garage | No garages |
| Occ. Descr. | Single-Family / Owner Occupied | Ttl Rooms Below # | 0 | Bedrooms Below # | 0 | Shower Stall Bath | 1 | Year Built | 1909 | Style | |
| Year Built | 1909 | Bsmt Fin Area #1 | | | | Toilet Room | | EFA | 100 | W X L | |
| EFA / EFYr | 100 / 1909 | Bsmt Fin Area #2 | | | | Lavatory | | EFA Year | 1909 | Area (SF) | |
| Arch. Dsgn | N/A | Bsmt Fin Area #3 | | | | Water Closet | | Style | 1 Sty Frm | Year Built | |
| Style | 1 1/2 Story Frame | Foundation | C Blk | | | Sink | | Area (SF) | 140 | EFA | |
| AreaSF/TLA | 1,008 / 1,966 | Exterior Walls | Stl | | | Shower Stall/Tub | | Condition | Below Normal | EFF Year | |
| GLA 1st/2nd | 1,260 / 706 | Roof | Asph / Gable | | | Mtl St Sh Bath | | Bsmt (SF) | | Condition | |
| Condition | BL NML | Interior Finish | Plas | | | Mtl Stall Shower | | NoBsmt Flr(SF) | | Bsmt (SF) | |
| Basement | Full | Flooring | Carp / Tile / Hdwd | | | No Bathroom | | Heat | Yes | Qtrs Over | |
| No Bsmt Flr. | 0 | Non-base Heating | | Fireplace | | Wet Bar | | AC | Yes | Qtrs Over (SF) | |
| Heat | Yes | Floor/Wall # | 0 | | | Whirlpool Bathroom | | Attic (SF) | | Qtrs AC (SF) | |
| AC | Yes | Pipeless # | 0 | | | Whirlpool Tub | | See other pages for more additions. | | | |
| Attic | None | Hand Fired (Y/N) | No | | | No Hot Water Tank | | | | Door Opnrs | |
| | | Space Heat # | 0 | | | No Plumbing | | | | Bsmt Stalls | |
| | | Appliances | | | | Sewer & Water Only | | | | | |
| | | Range Unit | Built-In Vacuums | | | Water Only w/Sink | | | | | |
| | | Oven - Single | Intercom System | | | Hot Tub | | | | | |
| | | Oven - Double | BI Stereo | | | Bidet | | | | | |
| | | Dishwasher | | | | FbglS Service Sink | | | | | |
| | | Microwave | | | | Urinal | | | | | |
| | | Trash Compactor | | | | Sauna | | | | | |
| | | Jennair | | | | W'Pool Bath w/Shower | | | | | |
| | | Security System | | | | Water Only | | | | | |
| | | | | | | No Tub/Shower | | | | | |



| Bldg / Addn | Description | Units | Year | | | |
|-------------|--------------------------------------|--------|------|--|--|--|
| 1 of 1 | 101 — Single-Family / Owner Occupied | | | | | |
| | 1 1/2 Story Frame | 1,008 | | | | |
| | Base Heat | | | | | |
| | Add Central Air | 1,008 | | | | |
| | Plumbing | 2 | | | | |
| 1 of 2 | Adtn 1 Story Frame | 140 SF | 1909 | | | |
| 2 of 2 | Adtn 1 Story Frame | 112 SF | 1909 | | | |

| | Count | Ag Building Description | Units | Year | | | | | |
|------------------|-------|----------------------------------------------|--------------------|------|--|--|--|--|--|
| 1 of 10 P:1 | 1 | LS FR @ .40 906-Barn - Flat | 42' X 48' 2,016 SF | 1900 | | | | | |
| 2 of 10 P:2 | 1 | SHED FR @ .20 908-Lean-To | 16' X 42' 672 SF | 1900 | | | | | |
| 3 of 10 P:3 | 1 | HOG HSE FR @ .20 927-Shed | 18' X 24' 432 SF | 1900 | | | | | |
| 4 of 10 P:4 | 1 | SHED FR @ .20 908-Lean-To | 15' X 24' 360 SF | 1900 | | | | | |
| 5 of 10 P:5 | 1 | HOG HSE FR @ .40 927-Shed | 24' X 30' 720 SF | 1900 | | | | | |
| 6 of 10 P:6 | 1 | STORAGE @ SV 904-Bin - Stl. Grain Storage | 14' X 11' 1,436 Bu | 1900 | | | | | |
| 7 of 10 P:8 | 1 | STORAGE 904-Bin - Stl. Grain Storage | 18' X 21' 4,552 Bu | 1978 | | | | | |
| 8 of 10 P:9 | 1 | STORAGE 904-Bin - Stl. Grain Storage | 18' X 16' 3,468 Bu | 1975 | | | | | |
| 9 of 10 P:10 | 1 | MACH FR @ .20 927-Shed | 18' X 24' 432 SF | 1900 | | | | | |
| 10 of 10 P:11 | 1 | MTL POLE 925-Steel Utility Bldg | 40' X 60' 2,400 SF | 1971 | | | | | |

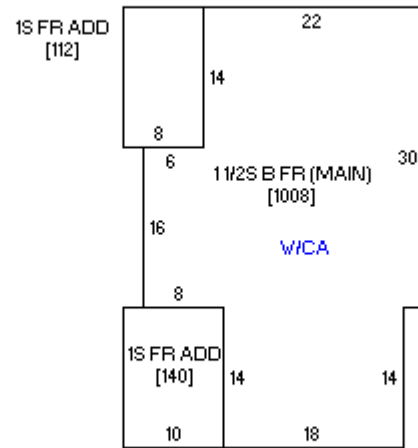

Sketch 1 of 1



Photo 1 of 1, 07/23/2008