

Pin: 09-19-300-004  
Sale Date: 05/30/13  
Sale Price: \$95,000  
Acres: .31 Net  
Classification: Rural Residential

09-19-300-004

#10949.25

R-Res



DET  
MTL  
GAR



LEGAL DESCRIPTION:

CLASS:

19-91-38 R RESIDENTIAL  
ALTA NOKOMIS  
PT. W 1/2 E 1/2 SW

-----		CSR'S	.00	-----	
				CODE	VALUE ACRES
GROSS	CURRENT				
ROADS	LAND	15,700			
D.D.	BLDG				
R.R.	DWLG	64,050( 1)			
MISC					
	TOTAL	79,750			
NET	.39				

=====		YEAR	2013	=====	
	LAND	15,700			
	BLDG				
	DWLG	64,050( 1)			
	TOTAL	79,750			
	NET TX				

DEED HOLDER:	DATE REFER	CONTRACT HOLDER:	DATE REFER	YEAR	2012
NAMANNY COREY L	07112013 4			LAND	15,700
NAMANNY AMANDA S				BLDG	
147 580TH ST				DWLG	64,050( 1)
ALTA IA 51002				TOTAL	79,750
				NET TX	

DEED HOLDER:	DATE REFER	CONTRACT HOLDER:	DATE REFER	YEAR	2011
ROBERTSON JACOB	12092003 3			LAND	15,700
DE LANCE AMBER				BLDG	
5648 10TH AVE				DWLG	64,050( 1)
ALTA IA 51002				TOTAL	79,750
				NET TX	

DEED HOLDER:	DATE REFER	CONTRACT HOLDER:	DATE REFER	YEAR	2010
BAKER STEVEN M	03021995 2			LAND	15,700
147 580TH ST				BLDG	
ALTA IA				DWLG	64,050( 1)
				TOTAL	79,750
				NET TX	

DEED HOLDER:	DATE REFER	CONTRACT HOLDER:	DATE REFER	YEAR	2009
PATTEN MARK A	1			LAND	15,700
1191 440TH ST				BLDG	
SIOUX RAPIDS IA				DWLG	64,050( 1)
				TOTAL	79,750
				NET TX	

REMARKS:	YEAR	2008
1 W.D. 51/524 09-05-80 \$4,000	LAND	9,850
2 W.D. 60/681 02-08-95 \$32,000 (D000)	BLDG	
3 W.D. #034786 10-27-03 \$65,000 (D000)	DWLG	50,820( 1)
4 W.D. #131712 05-30-13 \$95,000	TOTAL	60,670
	NET TX	

147 580TH ST, ALTA

Deed: **NAMANNY COREY L, NAMANNY AMANDA S**  
 Contract:  
 CID#: **1094925**  
 DBA:  
 MLS: **16350**

Map Area: **NOKOMIS-RES**  
 Route: **909-001-630**  
 Tax Dist: **ALTA NOKOMIS**  
 Plat Page:  
 Subdiv: **[NONE]**

Checks/Tags:  
 Lister/Date: **MA, 07/30/2008**  
 Review/Date: **DS, 11/05/2008**  
 Entry Status: **Inspected**

**RURAL/RESIDENTIAL**

Legal: 19-91-38 ALTA NOKOMIS PT. W 1/2 E 1/2 SW

Land									
Land Basis	Front	Rear	Side 1	Side 2	R. Lot	SF	Acres		
<b>Site-Excess</b>							0.390		
Sub Total						16,988.40	0.390		
<b>Grand Total</b>						16,988.40	0.390		

Sales				Building Permits				Values			
Date	\$ Amount	NUTC	Recording	Date	Number	Tag	\$ Amount	Reason			
05/30/2013	\$95,000	D0	131712								
10/27/2003	\$65,000	D0	#034786								
02/08/1995	\$32,000	D0	060-681								

Res. Structure		1 of 1		Finish				Plumbing				Addition		Garage	
Occ. Code	101	Ttl Rooms Above #	6	Bedrooms Above #	2	Full Bath	1	Addition	1 of 1	Garage	1 of 1				
Occ. Descr.	Single-Family / Owner Occupied	Ttl Rooms Below #	0	Bedrooms Below #	0	Shower Stall Bath		Year Built	1900	Style	Det Metal				
Year Built	1900	Bsmt Fin Area #1				Toilet Room		EFA	60	W X L	0' X 0'				
EFA / EFYr	60 / 1949	Bsmt Fin Area #2				Lavatory		EFA Year	1949	Area (SF)	1,344				
Arch. Dsgn	N/A	Bsmt Fin Area #3				Water Closet	1	Style	1 Sty Frm	Year Built	2008				
Style	1 1/2 Story Frame	Foundation	C Bik			Sink		Area (SF)	264	EFA	1				
AreaSF/TLA	512 / 1,134	Exterior Walls	Stl			Shower Stall/Tub		Condition	Normal	EFF Year	2008				
GLA 1st/2nd	776 / 358	Roof	Asph / Gable			Mtl St Sh Bath				Condition	NML				
		Interior Finish	Panel			Mtl Stall Shower		Bsmt (SF)	264	Bsmt (SF)					
		Flooring	Carp / Vinyl			No Bathroom		NoBsmt Flr(SF)		Qtrs Over	None				
		<b>Non-base Heating</b>		<b>Fireplace</b>		Wet Bar		Heat	FHA - Gas	Qtrs Over (SF)					
		Floor/Wall #	0			Whirlpool Bathroom		AC	Yes	Qtrs AC (SF)					
		Pipeless #	0			Whirlpool Tub		Attic (SF)							
		Hand Fired (Y/N)	No			No Hot Water Tank				Door Opnrs					
		Space Heat #	0			No Plumbing				Bsmt Stalls					
Condition	NML	<b>Appliances</b>				Sewer & Water Only									
		Range Unit		Built-In Vacuums		Water Only w/Sink									
Basement	Full	Oven - Single		Intercom System		Hot Tub									
No Bsmt Flr.	0	Oven - Double		Bl Stereo		Bidet									
Heat	FHA - Gas	Dishwasher				Fbgl's Service Sink	1								
AC	Yes	Microwave				Urinal									
Attic	None	Trash Compactor				Sauna									
		Jennair				W'Pool Bath w/Shower									
		Security System				Water Only									
						No Tub/Shower									



Bldg / Addn 1 of 1	Description	Units	Year
	101 — Single-Family / Owner Occupied		
	1 1/2 Story Frame	512	
	Base Heat: FHA - Gas		
	Add Central Air	512	
#1	Porch: 1S Frame Enclosed	195 SF	
	Basement Adjustment	195 SF	
	Deck #1: Wood Deck-Med	216 SF	
	Deck #2: Concrete Patio-Med	204 SF	
	Plumbing	3	
1 of 1 Adtn	1 Story Frame	264 SF	1900
	Garage: Det Metal 0' X 0'	1,344 SF	2008

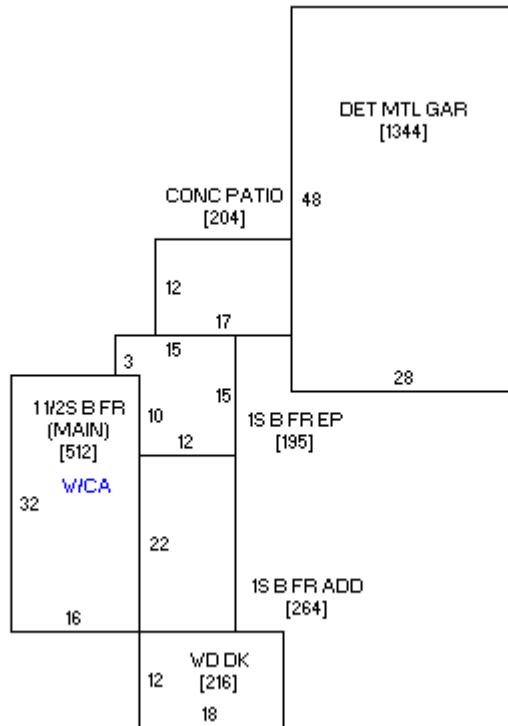

Sketch 1 of 1

