

08-36-400-004

7926.50
~~10~~

R-Res



Pin: 08-36-400-004
Sale Date 11/25/14
Sale Price: \$36,000
Acres: 5.90 Net
Classification: Rural Residential



13

8

7 NV

6

Att shed
← 6

5

4

3

LEGAL DESCRIPTION:	CLASS:	-----	CSR'S	.00	-----	CODE	VALUE	ACRES
36-92-35	R RESIDENTIAL		GROSS	6.20	CURRENT			
A.C.T. FAIRFIELD			ROADS	.30	LAND	21,500		
6.20 AC SE SE			D.D.		BLDG			
			R.R.		DWLG	26,860(1)		
			MISC					
					TOTAL	48,360		
			NET	5.90				

-----		-----		-----		-----	
		YEAR	2014				
		LAND	21,500	ROAD		.30	
		BLDG					
		DWLG	26,860(1)				
		TOTAL	48,360				
		NET TX					

DEED HOLDER:	DATE REFER	CONTRACT HOLDER:	DATE REFER	YEAR	2013	-----	-----
PEPDERSEN MATTHEW J	01022015 3			LAND	21,500	ROAD	.30
PEPDERSEN ERIN L				BLDG			
313 BENNETT AVE				DWLG	26,860(1)		
LUTHER IA 50152				TOTAL	48,360		
				NET TX			

-----	-----	-----	-----	YEAR	2012	-----	-----
ORWIG BECKY J	06062001 2	..		LAND	21,500	ROAD	.30
ORWIG STEVEN A				BLDG			
1342 440TH ST				DWLG	26,230(1)		
SIOUX RAPIDS IA 50585-2005				TOTAL	47,730		

-----	-----	-----	-----	YEAR	2011	-----	-----
NORDINE EVERETT R	06042001	ORWIG BECKY J	1	NET TX			
NORDINE SANDRA T		ORWIG STEVEN A					
GOCHNAUER VALERIE M		5373 250TH AVE		YEAR	2011		
GOCHNAUER CARL R		ALBERT CITY IA 50510		LAND	21,500	ROAD	.30

-----	-----	-----	-----	YEAR	2010	-----	-----
NORDINE EVERETT R	6	.		BLDG			
NORDINE SANDRA T				DWLG	26,230(1)		
GOCHNAUER CARL R				TOTAL	47,730		
				NET TX			

-----	-----	-----	-----	YEAR	2010	-----	-----
REMARKS:				LAND	21,500	ROAD	.30
1 CONT #011499 03-07-00 \$14,985				BLDG			
2 W.D. #062594-95 04-07-06				DWLG	26,230(1)		
3 W.D. #142979 11-25-14 \$36,000				TOTAL	47,730		
				NET TX			

-----	-----	-----	-----	YEAR	2009	-----	-----
				LAND	21,500	ROAD	.30
				BLDG			
				DWLG	26,230(1)		
				TOTAL	47,730		
				NET TX			

Deed: PEDERSEN MATTHEW J, PEDERSEN ERIN L
 Contract:
 CID#: 0792650
 DBA:
 MLS: 14911

Map Area: FAIRFIELD-RES
 Route: 905-001-99F
 Tax Dist: ACT FAIRFIELD
 Plat Page: -
 Subdiv: [NONE]

Checks/Tags: S
 Lister/Date: JF, 09/25/2008
 Review/Date: DS, 10/23/2008
 Entry Status: Inspected

RURAL/RESIDENTIAL
 Legal: 36-92-35 A.C.T. FAIRFIELD 6.20 AC SE SE

Land									
Land Basis	Front	Rear	Side 1	Side 2	R. Lot	SF	Acres		
Site-Excess							1.000		
Excess 1							4.900		
Sub Total						257,004.00	5.900		
Grand Total						257,004.00	5.900		

Sales				Building Permits				Values			
Date	\$ Amount	NUTC	Recording	Date	Number	Tag	\$ Amount	Reason			
11/25/2014	\$36,000	D0	142979	9/25/2008		R	\$0	Int-Remodel			
04/07/2006	\$0	D22	062594								
03/07/2001	\$14,985	C0	#011499								
09/28/1995	\$22,000	D26									

Res. Structure	1 of 1		Finish				Plumbing		Addition		Garage	
Occ. Code	101		Ttl Rooms Above #	7	Bedrooms Above #	4	Full Bath	1	Addition	1 of 3	Garage	No garages
Occ. Descr.	Single-Family / Owner Occupied		Ttl Rooms Below #	0	Bedrooms Below #	0	Shower Stall Bath		Year Built	1880	Style	
Year Built	1880		Bsmt Fin Area #1				Toilet Room		EFA	129	W X L	
EFA / EFYr	129 /	1880	Bsmt Fin Area #2				Lavatory		EFA Year	1880	Area (SF)	
Arch. Dsgn	N/A		Bsmt Fin Area #3				Water Closet		Style	1 Sty Frm	Year Built	
Style	1 1/2 Story Frame		Foundation	C Blk			Sink		Area (SF)	48	EFA	
AreaSF/TLA	756 /	1,819	Exterior Walls	Asb			Shower Stall/Tub		Condition	Poor	EFF Year	
GLA 1st/2nd	1,074 /	745	Roof	Asph / Gable			Mtl St Sh Bath		Bsmt (SF)		Condition	
			Interior Finish	Plas / Drwl			Mtl Stall Shower		NoBsmt Flr(SF)		Bsmt (SF)	
			Flooring	Carp / Vinyl			No Bathroom		Heat	Elec - Basebd	Qtrs Over	
			Non-base Heating		Fireplace		Wet Bar		AC	No	Qtrs Over (SF)	
			Floor/Wall #	0			Whirlpool Bathroom		Attic (SF)		Qtrs AC (SF)	
			Pipeless #	0			Whirlpool Tub		See other pages for more additions.			
			Hand Fired (Y/N)	No			No Hot Water Tank				Door Opnrs	
Condition	Poor		Space Heat #	0			No Plumbing				Bsmt Stalls	
			Appliances				Sewer & Water Only					
Basement	1/2		Range Unit	Built-In Vacuums			Water Only w/Sink					
No Bsmt Flr.	0		Oven - Single	Intercom System			Hot Tub					
Heat	Elec - Basebd		Oven - Double	Bl Stereo			Bidet					
AC	No		Dishwasher				Fbgl Service Sink					
Attic	None		Microwave				Urinal					
			Trash Compactor				Sauna					
			Jennair				W'Pool Bath w/Shower					
			Security System				Water Only					
							No Tub/Shower					



Bldg / Addn	Description	Units	Year			
1 of 1	101 — Single-Family / Owner Occupied					
	1 1/2 Story Frame	756				
	Adjustment for basement - 1/2					
	Base Heat: Elec - Basebd					
#1	Porch: 1S Frame Enclosed	90 SF				
#2	Porch: 1S Frame Open	6 SF				
1 of 3 Adtn	1 Story Frame	48 SF	1880			
2 of 3 Adtn	1 Story Frame	216 SF	1880			
	Basement area	216 SF				
3 of 3 Adtn	1 Story Frame	54 SF	1880			

	Count	Ag Building Description	Units	Year					
1 of 6 P:3	1	HOG HSE TILE @ .40 927-Shed	22' X 34' 748 SF	1900					
2 of 6 P:4	1	L FR @ .40 906-Barn - Flat	22' X 60' 1,320 SF	1900					
3 of 6 P:5	1	SHED MTL @ .20 908-Lean-To	18' X 24' 432 SF	1900					
4 of 6 P:6	1	OPEN FR @ .20 927-Shed	14' X 24' 336 SF	1900					
5 of 6 P:7	1	MACH MTL POLE @ .40 908-Lean-To	20' X 28' 560 SF	1900					
6 of 6 P:8	1	MACH FR @ .40 927-Shed	18' X 44' 792 SF	1900					

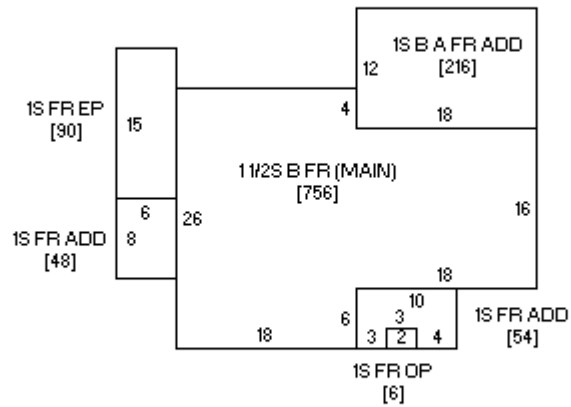



Photo 1 of 1 10/07/2008