

LEGAL DESCRIPTION:

CLASS:

02-06 R RESIDENTIAL
SL HAYES S-W S SD
CASINO BEACH

-----		CSR'S	.00	-----	
				CODE	VALUE ACRES
GROSS	CURRENT				
ROADS	LAND	72,450			
D.D.	BLDG				
R.R.	DWLG	177,820(1)			
MISC					
	TOTAL	250,270			
NET					

=====		=====	=====	=====	
	YEAR	2014			
	LAND	72,450			
	BLDG				
	DWLG	177,820(1)			
	TOTAL	250,270			
	NET TX				

DEED HOLDER:	DATE REFER	CONTRACT HOLDER:	DATE REFER	YEAR	2013	
MC KENNA JON D & PATTI J	01062015 2			LAND	72,450	
FAMILY TRUST				BLDG		
142 SCOTT ST				DWLG	177,820(1)	
STORM LAKE IA 50588				TOTAL	250,270	
				NET TX		

MOORE RICHARD R	1			YEAR	2012	
MOORE PATRICIA J				LAND	72,450	
142 SCOTT ST				BLDG		
STORM LAKE IA 50588				DWLG	177,820(1)	
				TOTAL	250,270	
				NET TX		

				YEAR	2011	
				LAND	72,450	
				BLDG		
				DWLG	177,820(1)	
				TOTAL	250,270	
				NET TX		

				YEAR	2010	
				LAND	72,450	
				BLDG		
				DWLG	177,820(1)	
				TOTAL	250,270	
				NET TX		

				YEAR	2009	
				LAND	72,450	
				BLDG		
				DWLG	166,050(1)	
				TOTAL	238,500	
				NET TX		

REMARKS:
1 W.D. 52/70 11-20-81 \$38,500
2 W.D. #142880 11-06-14 \$357,000

Deed: MC KENNA JON D & PATTI J,FAMILY TRUST
 Contract:
 CID#: 0949400
 DBA:
 MLS: 17359

Map Area: HAYES-RES(CASINO)
 Route: 915-001-450
 Tax Dist: SL HAYES S-W S SD
 Plat Page: -
 Subdiv: [NONE]

Checks/Tags: S
 Lister/Date: LF, 06/25/2008
 Review/Date: TG, 11/26/2008
 Entry Status: Estimated

RURAL/RESIDENTIAL

Legal: 02-06 SL HAYES S-W S SD CASINO BEACH

Land										
Land Basis	Front	Rear	Side 1	Side 2	R. Lot	SF	Acres			
FF Main	45.00	45.00	105.75	101.50	0.00					
Sub Total						4,663.13	0.107			
Grand Total						4,663.13	0.107			

Sales				Building Permits				Values			
Date	\$ Amount	NUTC	Recording	Date	Number	Tag	\$ Amount	Reason			
11/06/2014	\$357,000	D0	142880								
11/20/1981	\$38,500	D0									

Res. Structure	1 of 1	Finish				Plumbing			Addition		Garage	
Occ. Code	101	Ttl Rooms Above #	7	Bedrooms Above #	4	Full Bath	1	Addition	1 of 1	Garage	1 of 1	
Occ. Descr.	Single-Family / Owner Occupied	Ttl Rooms Below #	0	Bedrooms Below #	0	Shower Stall Bath	1	Year Built	1981	Style	Att Frm	
Year Built	1994	Bsmt Fin Area #1	300	Table		Toilet Room	1	EFA	28	W X L	0' X 0'	
EFA / EFYr	15 / 1994	Bsmt Fin Area #2				Lavatory		EFA Year	1981	Area (SF)	624	
Arch. Dsgn	N/A	Bsmt Fin Area #3				Water Closet		Style	1 Sty Frm	Year Built	1982	
Style	2 Story Frame	Foundation	C Bk			Sink		Area (SF)	396	EFA	27	
AreaSF/TLA	702 / 1,800	Exterior Walls	Vinyl			Shower Stall/Tub		Condition	Above Normal	EFF Year	1982	
GLA 1st/2nd	1,098 / 702	Roof	Mtl / Hip			Mtl St Sh Bath		Bsmt (SF)		Condition	A NML	
		Interior Finish	DRYWALL/HARDWOOD			Mtl Stall Shower		NoBsmt Flr(SF)		Bsmt (SF)		
		Flooring	Carp / Ceramic			No Bathroom		Heat	FHA - Gas	Qtrs Over	None	
		Non-base Heating		Fireplace		Wet Bar		AC	Yes	Qtrs Over (SF)		
		Floor/Wall #	0	Gas/Elec-Side, 1 Sty	2	Whirlpool Bathroom		Attic (SF)		Qtrs AC (SF)		
		Pipeless #	0			Whirlpool Tub						
		Hand Fired (Y/N)	No			No Hot Water Tank						
Condition	NML	Space Heat #	0			No Plumbing				Door Opnrs		
		Appliances				Sewer & Water Only				Bsmt Stalls		
Basement	Full	Range Unit	Built-In Vacuums			Water Only w/Sink						
No Bsmt Flr.	0	Oven - Single	Intercom System			Hot Tub						
Heat	FHA - Gas	Oven - Double	BI Stereo			Bidet						
AC	Yes	Dishwasher				FbglS Service Sink						
Attic	None	Microwave				Urinal						
		Trash Compactor				Sauna						
		Jennair				W'Pool Bath w/Shower						
		Security System				Water Only						
						No Tub/Shower						



Bldg / Addn	Description	Units	Year
1 of 1	101 — Single-Family / Owner Occupied		
	2 Story Frame	702	
#1	Bsmt Fin - Rec. Room W/ Walk-out (Avg)	300 Tbl	
	Base Heat: FHA - Gas		
	Add Central Air	702	
#1	Porch: 1S Frame Enclosed	364 SF	
	Deck #1: Wood Deck-Med	241 SF	
	Deck #2: Concrete Patio-Med	336 SF	
	Plumbing	3	
#1	Fireplace: Gas/Elec-Side, 1 Story	2	
	Garage: Att Frame	624 SF	1982
1 of 1	Adtn 1 Story Frame	396 SF	1981

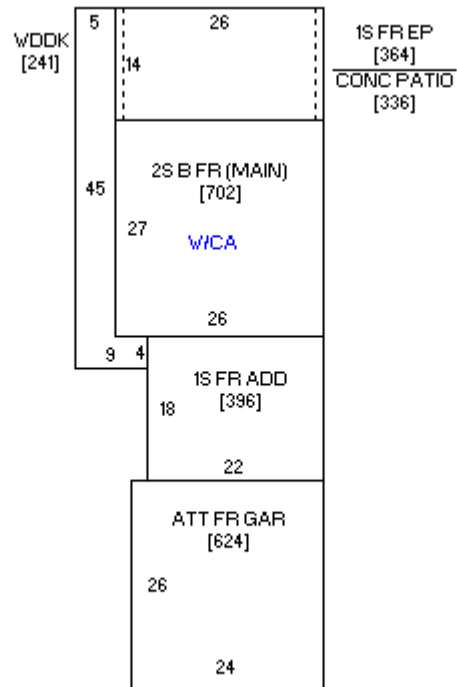

Sketch 1 of 1

