

LEGAL DESCRIPTION:	CLASS:	-----	CSR'S	.00	CODE	VALUE ACRES
05-01	R RESIDENTIAL	GROSS	CURRENT			
SL HAYES S-W S SD		ROADS	LAND	250,630		
SOUTH COVE ADD.		D.D.	BLDG			
		R.R.	DWLG	196,230(1)		
		MISC				
			TOTAL	446,860		
		NET				

-----		-----		-----	
		YEAR	2013		
		LAND	250,630		
		BLDG			
		DWLG	196,230(1)		
		TOTAL	446,860		
		NET TX			

DEED HOLDER:	DATE REFER	CONTRACT HOLDER:	DATE REFER	YEAR	2012
LENHART BRAD A	03132014 4			LAND	250,630
LENHART DONNA M				BLDG	
153 SOUTH COVE DR				DWLG	196,230(1)
STORM LAKE IA 50588				TOTAL	446,860
				NET TX	

-----		-----		-----	
		YEAR	2011		
		LAND	250,630		
		BLDG			
		DWLG	196,230(1)		
		TOTAL	446,860		
		NET TX			

-----		-----		-----	
		YEAR	2010		
		LAND	250,630		
		BLDG			
		DWLG	196,230(1)		
		TOTAL	446,860		
		NET TX			

-----		-----		-----	
		YEAR	2009		
		LAND	250,630		
		BLDG			
		DWLG	196,230(1)		
		TOTAL	446,860		
		NET TX			

-----		-----		-----	
REMARKS:		YEAR	2008		
1 W.D. 59/965 02-01-94 \$162,500 (D000)		LAND	196,200		
2 Affidavit 35/677 02-17-94		BLDG			
3 W.D. #012684 08-20-01 \$335,000 (D000)		DWLG	180,000(1)		
4 W.D. #140380 01-30-14 \$390,000		TOTAL	376,200		
		NET TX			

-----		-----		-----	
		YEAR	2009		
		LAND	250,630		
		BLDG			
		DWLG	196,230(1)		
		TOTAL	446,860		
		NET TX			

153 SOUTH COVE DR, STORM LAKE

Deed: **LENHART BRAD A,LENHART DONNA M**

Map Area: **HAYES-RES(S.COVE)**

Checks/Tags:

Contract:

Route: **915-002-350**

Lister/Date: **TG, 06/12/2008**

CID#: **0956600**

Tax Dist: **SL HAYES S-W S SD**

Review/Date: **TG, 12/01/2008**

DBA:

Plat Page: -

Entry Status: **Inspected**

MLS: **16694**

Subdiv: **[NONE]**

RURAL/RESIDENTIAL

Legal:05-01 SL HAYES S-W S SD SOUTH COVE ADD.

Land										
Land Basis	Front	Rear	Side 1	Side 2	R. Lot	SF	Acres			
FF Main	150.05	171.00	210.00	210.00	0.00					
Sub Total						33,710.25	0.774			
Grand Total						33,710.25	0.774			

Sales				Building Permits				Values			
Date	\$ Amount	NUTC	Recording	Date	Number	Tag	\$ Amount	Reason			
01/30/2014	\$390,000	D0	140380								
08/20/2001	\$335,000	D0	#012684								
02/01/1994	\$162,500	D22	059-965								

Res. Structure		Finish				Plumbing		Addition		Garage	
Occ. Code	101	Ttl Rooms Above #	9	Bedrooms Above #	3	Full Bath	2	Addition	1 of 4	Garage	1 of 1
Occ. Descr.	Single-Family / Owner Occupied	Ttl Rooms Below #	0	Bedrooms Below #	0	Shower Stall Bath	1	Year Built	1975	Style	Att Frm
Year Built	1975	Bsmt Fin Area #1				Toilet Room		EFA	34	W X L	0' X 0'
EFA / EFYr	34 / 1975	Bsmt Fin Area #2				Lavatory		EFA Year	1975	Area (SF)	1,028
Arch. Dsgn	N/A	Bsmt Fin Area #3				Water Closet		Style	1 Sty Frm	Year Built	1994
Style	1 Story Frame	Foundation	C Blk			Sink	1	Area (SF)	632	EFA	15
AreaSF/TLA	1,692 / 3,108	Exterior Walls	Stl			Shower Stall/Tub		Condition	Normal	EFF Year	1994
GLA 1st/2nd	3,108 / 0	Roof	Asph / Gable			Mtl St Sh Bath		Bsmt (SF)		Condition	NML
Condition	NML	Interior Finish	Drwl			Mtl Stall Shower		NoBsmt Flr(SF)		Bsmt (SF)	
Basement	1/4	Flooring	Carp / Vinyl			No Bathroom		Heat	FHA - Gas	Qtrs Over	None
No Bsmt Flr.	0	Non-base Heating		Fireplace		Wet Bar		AC	Yes	Qtrs Over (SF)	
Heat	FHA - Gas	Floor/Wall #	0	Masonry, 1 Sty	1	Whirlpool Bathroom		Attic (SF)		Qtrs AC (SF)	
AC	Yes	Pipeless #	0			Whirlpool Tub		See other pages for more additions.			
Attic	None	Hand Fired (Y/N)	No			No Hot Water Tank		Door Opnrs		Bsmt Stalls	
		Space Heat #	0			No Plumbing					
		Appliances				Sewer & Water Only					
		Range Unit	Built-In Vacuums			Water Only w/Sink					
		Oven - Single	Intercom System			Hot Tub					
		Oven - Double	Bl Stereo			Bidet					
		Dishwasher				FbglS Service Sink	1				
		Microwave				Urinal					
		Trash Compactor				Sauna					
		Jennair				W'Pool Bath w/Shower					
		Security System				Water Only					
						No Tub/Shower					



Bldg / Addn 1 of 1	Description	Units	Year
	101 — Single-Family / Owner Occupied		
	1 Story Frame	1,692	
	Adjustment for basement - 1/4		
	Base Heat: FHA - Gas		
	Add Central Air	1,692	
#1	Porch: 1S Frame Open	40 SF	
	Deck #1: Wood Deck-Med	566 SF	
	Deck #2: Asph/Wd Roof OH-High	66 SF	
	Veneer #1 1 Story Brick	27.0 LF	
	Veneer #2 1/2 Story Brick	34.0 LF	
	Plumbing	5	
#1	Fireplace: Masonry, 1 Story	1	
	Garage: Att Frame	1,028 SF	1994
BEx	GAZEBO	94 SF	
1 of 4	Adtn 1 Story Frame	632 SF	1975
2 of 4	Adtn 1 Story Frame	230 SF	1975
	Basement area	230 SF	
3 of 4	Adtn 1 Story Frame	90 SF	1994
4 of 4	Adtn 1 Story Frame	464 SF	1994

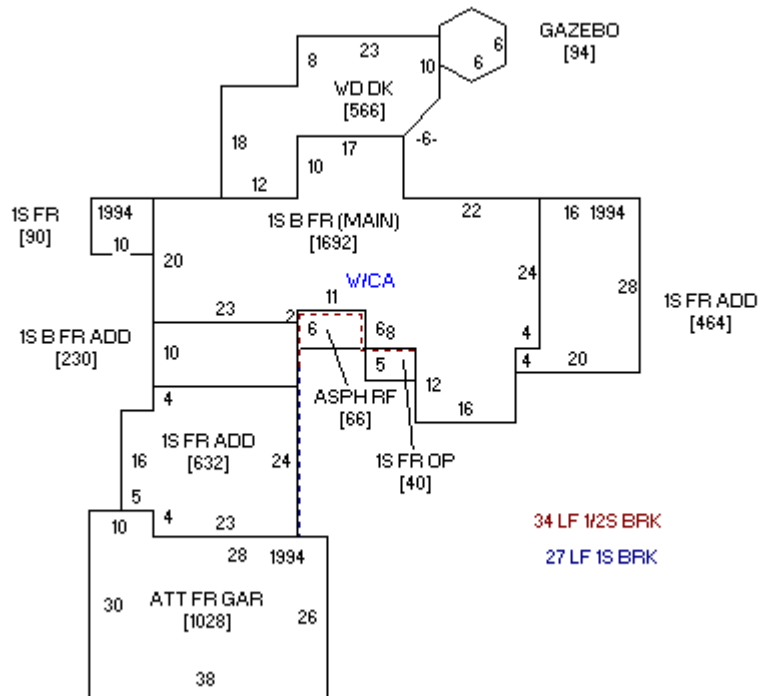



Photo 1 of 2 06/26/2008



Photo 2 of 2 05/01/1998