

08-27-100-005

7866.10

AG

Photo 1 of 3



08-27-100-006

#7866.50

R-Res

Pin: 08-27-100-006
Sale Date: 10-29-15
Sale Price: \$70,000
Acres: 3.69 Net
Classification: Change in Use from Ag to Rural Res

MKB 12/07/15
NEW
MANUFACTURED
HOME W/ WD DK

1

G

2

pp
↓

4

3

5

8

9

08

08

#11 - Bin
(36x22)

#10 - Bin
(21x16)

See Photo 2 of location of bins

LEGAL DESCRIPTION:

CLASS:

27-92-35
A.C.T. FAIRFIELD
LOT B IN NW NW

A AGRICULTURE

		CSR'S	291.79		
				CODE	VALUE ACRES
GROSS	3.99	CURRENT			
ROADS	.30	LAND	9,480		
D.D.		BLDG	8,480(7)		
R.R.		DWLG	31,680(1)		
MISC					
		TOTAL	49,640		
NET	3.69				

		YEAR	2016 REFER: 1		
		LAND	9,480		
		BLDG	8,480(7)		
		DWLG	31,680(1)		
		TOTAL	49,640		
		NET TX			

DEED HOLDER:

DATE REFER

CONTRACT HOLDER:

DATE REFER

YEAR 2015 REFER: 2

SIEVERS NICHOLAS A

01052016 3

5218 220TH AVE
ALBERT CITY IA 50510

LAND	9,480
BLDG	8,480(7)
DWLG	31,680(1)
TOTAL	49,640
NET TX	

DIERWECHTER FARMS INC

YEAR	
LAND	
BLDG	
DWLG	
TOTAL	
NET TX	

REMARKS:

- 1 !2016)SPLIT FROM -001 (01/05/16)
- 2 !2015)SPLIT FROM -001 (01/05/16)
- 3 WD #153095 10/29/15 \$70,000

YEAR	
LAND	
BLDG	
DWLG	
TOTAL	
NET TX	

Deed: SIEVERS NICHOLAS A
 Contract:
 CID#: 0000786650
 DBA:
 MLS:

Map Area: FAIRFIELD-AG
 Route: 905-001-720
 Tax Dist: ACT FAIRFIELD
 Plat Page: -
 Subdiv: [NONE]

Checks/Tags:
 Lister/Date: JF, 10/01/2008
 Review/Date: DS, 10/24/2008
 Entry Status: Inspected

RURAL/AG DWELLING

Legal: 27-92-35 A.C.T. FAIRFIELD LOT B IN NW NW

Land									
Land Basis	Front	Rear	Side 1	Side 2	R. Lot	SF	Acres		
Ag Land							3.690		
Grand Total						160,736.40	3.690		

Street	Utilities	Zoning	Land Use
None	None	Not Applicable	Not Applicable

Sales				Building Permits				Values			
Date	\$ Amount	NUTC	Recording	Date	Number	Tag	\$ Amount	Reason			
10/29/2015	\$70,000	D26	152258								

Res. Structure		Finish				Plumbing		Addition		Garage	
Occ. Code	101	Ttl Rooms Above #	6	Bedrooms Above #	3	Full Bath	1	Addition	1 of 1	Garage	1 of 1
Occ. Descr.	Single-Family / Owner Occupied	Ttl Rooms Below #	0	Bedrooms Below #	0	Shower Stall Bath		Year Built	1900	Style	Det Frm
Year Built	1900	Bsmt Fin Area #1				Toilet Room		EFA	109	W X L	0' X 0'
EFA / EFYr	109 / 1900	Bsmt Fin Area #2				Lavatory		EFA Year	1900	Area (SF)	280
Arch. Dsgn	N/A	Bsmt Fin Area #3				Water Closet		Style	1 Sty Frm	Year Built	1910
Style	1 1/2 Story Frame	Foundation	C Blk			Sink		Area (SF)	40	EFA	99
AreaSF/TLA	800 / 1,400	Exterior Walls	Alum			Shower Stall/Tub		Condition	Below Normal	EFF Year	1910
GLA 1st/2nd	840 / 560	Roof	Asph / Gable			Mtl St Sh Bath				Condition	Poor
		Interior Finish	Plas / Drwl / Panel			Mtl Stall Shower		Bsmt (SF)		Bsmt (SF)	
		Flooring	Carp / Vinyl			No Bathroom		NoBsmt Flr(SF)		Qtrs Over	None
		Non-base Heating		Fireplace		Wet Bar		Heat	FHA - Gas	Qtrs Over (SF)	
		Floor/Wall #	0			Whirlpool Bathroom		AC	No	Qtrs AC (SF)	
		Pipeless #	0			Whirlpool Tub		Attic (SF)			
		Hand Fired (Y/N)	No			No Hot Water Tank				Door Opnrs	
Condition	BL NML	Space Heat #	0			No Plumbing				Bsmt Stalls	
		Appliances				Sewer & Water Only					
Basement	Full	Range Unit	Built-In Vacuums			Water Only w/Sink					
No Bsmt Flr.	0	Oven - Single	Intercom System			Hot Tub					
Heat	FHA - Gas	Oven - Double	Bl Stereo			Bidet					
AC	No	Dishwasher				Fbgls Service Sink					
Attic	None	Microwave				Urinal					
		Trash Compactor				Sauna					
		Jennair				W'Pool Bath w/Shower					
		Security System				Water Only					
						No Tub/Shower					



Bldg / Addn	Description	Units		Year				
	101 — Single-Family / Owner Occupied							
	1 1/2 Story Frame	800						
	Base Heat: FHA - Gas							
	Deck #1: Concrete Patio-Med	105 SF						
Adtn	1 Story Frame	40 SF		1900				
	Garage: Det Frame 0' X 0'	280 SF		1910				

	Count	Ag Building Description	Units	Year
1 of 7 P:1	1	GRANARY FR @ .70 927-Shed	10' X 24' 240 SF	1900
2 of 7 P:2	1	HEN HSE TILE @ .90 927-Shed	14' X 30' 420 SF	1900
3 of 7 P:3	1	MTL POLE 925-Steel Utility Bldg	54' X 60' 3,240 SF	1986
4 of 7 P:4	1	ELEV. OHB L FR @ .90 926-Crib	27' X 28' 756 SF	1900
5 of 7 P:5	1	DRYER 904-Bin - Stl. Grain Storage	24' X 18' 7,054 Bu	1977
6 of 7 P:8	1	OPEN SHED FR @ .40 908-Lean-To	16' X 60' 960 SF	1900
7 of 7 P:9	1	FR @ .40 906-Barn - Flat	40' X 54' 2,160 SF	1900

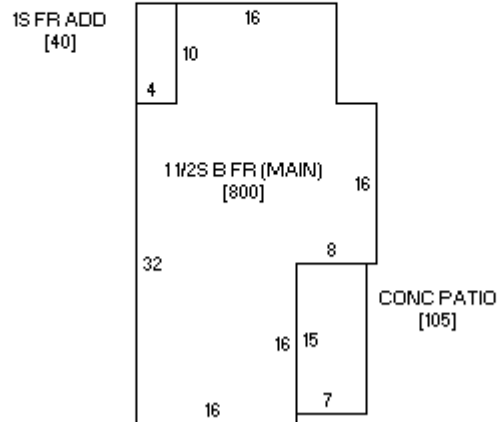
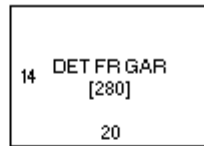



Photo 1 of 1, 10/27/2008