

Pin: 08-29-100-008
Sale Date: 09/18/15
Sale Price: \$210,000
Acres: 5.10 Net
Classification: Rural Residential

08-29-100-008

7877.⁵⁰₉₀

R-Res



2

05



LEGAL DESCRIPTION:

CLASS:

29-92-35
A.C.T. FAIRFIELD
LOT B IN E 1/2 NW

R RESIDENTIAL

| ----- | | CSR'S | .00 | ----- | |
|-------|------|---------|------------|-------|-------------|
| | | | | CODE | VALUE ACRES |
| GROSS | 5.13 | CURRENT | | | |
| ROADS | .03 | LAND | 20,800 | | |
| D.D. | | BLDG | | | |
| R.R. | | DWLG | 93,570(1) | | |
| MISC | | | | | |
| | | TOTAL | 114,370 | | |
| NET | 5.10 | | | | |

| ===== | | ===== | ===== | ===== | |
|-------|--|--------|---------------|-------|--|
| | | YEAR | 2015 REFER: 1 | | |
| | | LAND | 20,800 | | |
| | | BLDG | | | |
| | | DWLG | 93,570(1) | | |
| | | TOTAL | 114,370 | | |
| | | NET TX | | | |

| DEED HOLDER: | DATE REFER | CONTRACT HOLDER: | DATE REFER | YEAR | |
|-----------------|------------|------------------|------------|--------|--|
| J & S ACRES INC | 10272015 2 | | | LAND | |
| | | | | BLDG | |
| | | | | DWLG | |
| | | | | TOTAL | |
| | | | | NET TX | |

| | | | | | |
|--|--|--|--|--------|--|
| | | | | YEAR | |
| | | | | LAND | |
| | | | | BLDG | |
| | | | | DWLG | |
| | | | | TOTAL | |
| | | | | NET TX | |

| | | | | | |
|--|--|--|--|--------|--|
| | | | | YEAR | |
| | | | | LAND | |
| | | | | BLDG | |
| | | | | DWLG | |
| | | | | TOTAL | |
| | | | | NET TX | |

| | | | | | |
|--|--|--|--|--------|--|
| | | | | YEAR | |
| | | | | LAND | |
| | | | | BLDG | |
| | | | | DWLG | |
| | | | | TOTAL | |
| | | | | NET TX | |

REMARKS:

1 !2015)SPLIT FROM -007 (10/27/15)
2 WD #152300 09/18/15 \$210,000

| | | | | | |
|--|--|--|--|--------|--|
| | | | | YEAR | |
| | | | | LAND | |
| | | | | BLDG | |
| | | | | DWLG | |
| | | | | TOTAL | |
| | | | | NET TX | |

Deed: J & S ACRES INC
 Contract:
 CID#: 0787750
 DBA:
 MLS: 17756

Map Area: FAIRFIELD-RES
 Route: 905-001-760
 Tax Dist: ACT FAIRFIELD
 Plat Page: -
 Subdiv: [NONE]

Checks/Tags: S
 Lister/Date: JF, 09/30/2008
 Review/Date: DS, 10/24/2008
 Entry Status: Estimated

RURAL/RESIDENTIAL

Legal: 29-92-35 A.C.T. FAIRFIELD LOT B IN E 1/2 NW

| Land | | | | | | | | | |
|-------------|-------|------|--------|--------|--------|------------|-------|--|--|
| Land Basis | Front | Rear | Side 1 | Side 2 | R. Lot | SF | Acres | | |
| Site-Excess | | | | | | | 1.000 | | |
| Excess 1 | | | | | | | 4.100 | | |
| Sub Total | | | | | | 222,156.00 | 5.100 | | |
| Grand Total | | | | | | 222,156.00 | 5.100 | | |

| Street | Utilities | Zoning | Land Use |
|--------|---------------|----------------|----------------|
| Gravel | Septic / Well | Not Applicable | Not Applicable |

| Sales | | | | Building Permits | | | | Values | | | | |
|------------|-----------|------|-----------|------------------|--------|-----|-----------|--------|-------|--|-----------|--|
| Date | \$ Amount | NUTC | Recording | Date | Number | Tag | \$ Amount | Reason | Type | | Assessed | |
| 09/18/2015 | \$210,000 | D26 | 152300 | | | | | | Land | | \$20,800 | |
| 07/15/1997 | \$55,500 | D26 | 97/1897 | | | | | | LandC | | \$0 | |
| | | | | | | | | | Dwlg | | \$93,570 | |
| | | | | | | | | | Impr | | \$0 | |
| | | | | | | | | | Total | | \$114,370 | |

| Res. Structure | | Finish | | | | Plumbing | | Addition | | Garage | |
|----------------|-----------------------------------|-------------------------|--------------------------|------------------|---|----------------------|---|-------------------------------------|-----------|----------------|---------|
| Occ. Code | 101 | Ttl Rooms Above # | 8 | Bedrooms Above # | 4 | Full Bath | 1 | Addition | 1 of 3 | Garage | 1 of 1 |
| Occ. Descr. | Single-Family / Owner Occupied | Ttl Rooms Below # | 0 | Bedrooms Below # | 0 | Shower Stall Bath | | Year Built | 1990 | Style | Att Frm |
| Year Built | 1940 | Bsmt Fin Area #1 | | | | Toilet Room | 1 | EFA | 19 | W X L | 0' X 0' |
| EFA / EFYr | 69 / 1940 | Bsmt Fin Area #2 | | | | Lavatory | | EFA Year | 1990 | Area (SF) | 908 |
| Arch. Dsgn | N/A | Bsmt Fin Area #3 | | | | Water Closet | | Style | 1 Sty Frm | Year Built | 1990 |
| Style | 1 Story Frame | Foundation | C Blk | | | Sink | | Area (SF) | 762 | EFA | 19 |
| AreaSF/TLA | 728 / 2,141 | Exterior Walls | COMPO SHINGLES/SHEATHING | | | Shower Stall/Tub | | Condition | Normal | EFF Year | 1990 |
| GLA 1st/2nd | 1,741 / 400 | Roof | Asph / Gable | | | Mtl St Sh Bath | | Bsmt (SF) | | Condition | A NML |
| | | Interior Finish | Plas / Drwl | | | Mtl Stall Shower | | NoBsmt Flr(SF) | | Bsmt (SF) | |
| | | Flooring | Carp / Vinyl | | | No Bathroom | | Heat | FHA - Gas | Qtrs Over | None |
| | | Non-base Heating | | Fireplace | | Wet Bar | | AC | No | Qtrs Over (SF) | |
| | | Floor/Wall # | 0 | | | Whirlpool Bathroom | | Attic (SF) | | Qtrs AC (SF) | |
| | | Pipeless # | 0 | | | Whirlpool Tub | | See other pages for more additions. | | | |
| | | Hand Fired (Y/N) | No | | | No Hot Water Tank | | | | Door Opnrs | |
| Condition | A NML | Space Heat # | 0 | | | No Plumbing | | | | Bsmt Stalls | |
| | | Appliances | | | | Sewer & Water Only | | | | | |
| Basement | 1/2 | Range Unit | Built-In Vacuums | | | Water Only w/Sink | | | | | |
| No Bsmt Flr. | 0 | Oven - Single | Intercom System | | | Hot Tub | | | | | |
| Heat | FHA - Gas | Oven - Double | Bl Stereo | | | Bidet | | | | | |
| AC | No | Dishwasher | | | | FbglS Service Sink | | | | | |
| Attic | Fully Finished 400SF | Microwave | | | | Urinal | | | | | |
| | | Trash Compactor | | | | Sauna | | | | | |
| | | Jennair | | | | W'Pool Bath w/Shower | | | | | |
| | | Security System | | | | Water Only | | | | | |
| | | | | | | No Tub/Shower | | | | | |



Copyright © 1995-2014
Vanguard Appraisals, Inc.

| Bldg / Addn | Description | Units | Year | | | | |
|-------------|--------------------------------------|---------|------|--|--|--|--|
| 1 of 1 | 101 — Single-Family / Owner Occupied | | | | | | |
| | 1 Story Frame | 728 | | | | | |
| | Adjustment for basement - 1/2 | | | | | | |
| | Base Heat: FHA - Gas | | | | | | |
| | Add Fully Finished attic | 400 | | | | | |
| #1 | Porch: 1S Frame Screen | 260 SF | | | | | |
| | Deck #1: Concrete Patio-Med | 360 SF | | | | | |
| | Deck #2: Concrete Patio-Med | 160 SF | | | | | |
| | Deck #3: Concrete Patio-Med | 294 SF | | | | | |
| | Veneer #1 1/2 Story Brick | 26.0 LF | | | | | |
| | Plumbing | 2 | | | | | |
| | Garage: Att Frame | 908 SF | 1990 | | | | |
| 1 of 3 Adtn | 1 Story Frame | 762 SF | 1990 | | | | |
| 2 of 3 Adtn | 1 Story Frame | 20 SF | 1940 | | | | |
| 3 of 3 Adtn | 1 Story Frame | 231 SF | 1990 | | | | |

| Count | Ag Building Description | Units | Year |
|---------------|------------------------------------|--------------------|------|
| 1 of 1 P:2 | MTL POLE 925-Steel Utility Bldg | 46' X 70' 3,220 SF | 1973 |

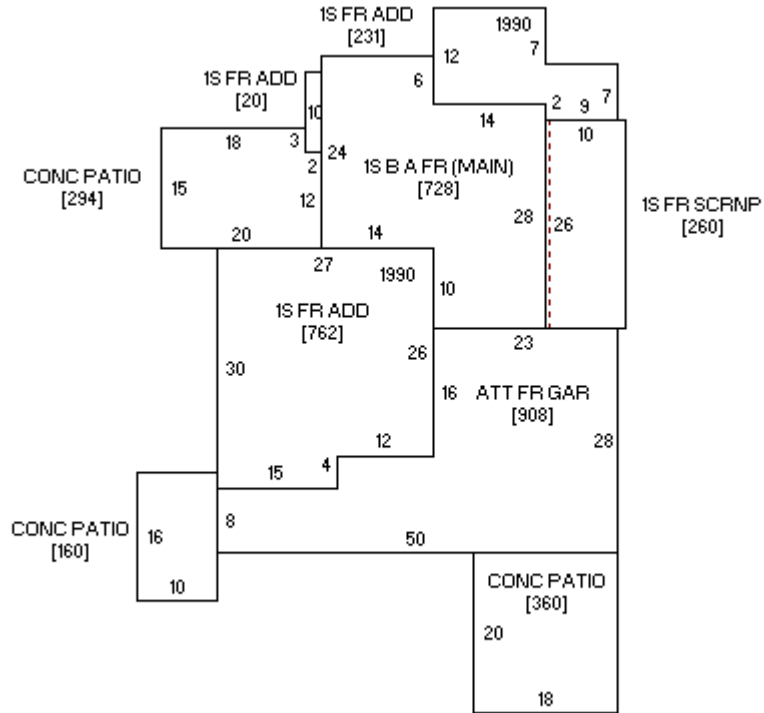

26 LF 1/2S BRK

Sketch 1 of 1

