

Pin: 11-26-400-005
Sale Date: 09/01/15
Sale Price: \$11,000
Acres: .90 Net
Classification: Rural Residential

11-26-400-005

#8630.00

R-Res

Page 1 of 2



95

96

Dwlg
Add.



NOV 26 2002

LEGAL DESCRIPTION:

CLASS:

26-91-36 R RESIDENTIAL
STORM LAKE GRANT
1 A SE SE

-----		CSR'S	.00		
				CODE	VALUE ACRES
GROSS	1.00	CURRENT			
ROADS	.10	LAND	8,890		
D.D.		BLDG			
R.R.		DWLG	1,870(1)		
MISC					
		TOTAL	10,760		
NET	.90				

=====		=====		=====	
		YEAR	2015		
		LAND	8,890	ROAD	.10
		BLDG			
		DWLG	1,870(1)		
		TOTAL	10,760		
		NET TX			

-----		-----		-----	
DEED HOLDER:	DATE REFER	CONTRACT HOLDER:	DATE REFER	YEAR	2014
MANDERNACH EILEEN B	09282015 5			LAND	8,550
				ROAD	.10
				BLDG	
				DWLG	1,800(1)
2070 570TH ST				TOTAL	10,350
NEWELL IA 50568				NET TX	

-----		-----		-----	
HELLER PAUL	03272000 4	...		YEAR	2013
				LAND	8,550
				ROAD	.10
				BLDG	
				DWLG	1,800(1)
1001 PALMER ST #1				TOTAL	10,350
EMMETSBURG IA 50536				NET TX	

-----		-----		-----	
SAMPSON JERRY	06131994 3	.		YEAR	2012
				LAND	8,550
				ROAD	.10
				BLDG	
				DWLG	1,800(1)
1793 590TH ST				TOTAL	10,350
P O BOX 855				NET TX	
STORM LAKE IA					

-----		-----		-----	
HAAHR DANA	2	.		YEAR	2011
				LAND	8,550
				ROAD	.10
				BLDG	
				DWLG	1,800(1)
HAAHR JOYCE				TOTAL	10,350
R R 2				NET TX	
NEWELL IA					

-----		-----		-----	
REMARKS:				YEAR	2010
				LAND	8,550
				ROAD	.10
				BLDG	
				DWLG	1,800(1)
				TOTAL	10,350
				NET TX	

-----		-----		-----	
-------	--	-------	--	-------	--

- 2 W.D. 60/264 04-01-91 (D022)
- 3 W.D. 60/294 05-26-94 \$6,300.20
- 4 W.D. #000616 01-28-00 \$6,000
- 5 W.D. #152240 09-01-15 \$11,000

PDF+PIN: 011+11-26-400-005
 1793 590TH ST, STORM LAKE

Buena Vista County Assessor

WORKING

Mon, 10/5/2015, 4:05 PM Page 1

Deed: **MANDERNACH EILEEN B**
 Contract:
 CID#: **0863000**
 DBA:
 MLS:

Map Area: **GRANT-RES**
 Route: **911-001-98F**
 Tax Dist: **SL GRANT**
 Plat Page: -
 Subdiv: **[NONE]**

Checks/Tags:
 Lister/Date: **LF, 08/29/2008**
 Review/Date: **DS, 11/13/2008**
 Entry Status: **Estimated**

RURAL/RESIDENTIAL

Legal:26-91-36 STORM LAKE GRANT 1 A SE SE

Land													
Land Basis	Front	Rear	Side 1	Side 2	R. Lot	SF	Acres						
Site-Excess							0.900						
Sub Total						39,204.00	0.900						
Grand Total						39,204.00	0.900						

Street	Utilities	Zoning	Land Use
Site-Excess Paved	Septic / Well	Not Applicable	Not Applicable

Sales				Building Permits					Values				
Date	\$ Amount	NUTC	Recording	Date	Number	Tag	\$ Amount	Reason	Type			Assessed	
09/01/2015	\$11,000	D0	152240	7/12/2002		N	\$10,000	New Bldg	Land			\$8,890	
01/28/2000	\$6,000	D0	#000616						LandC			\$0	
									Dwlg			\$1,870	
									Impr			\$0	
									Total			\$10,760	

Res. Structure		Finish				Plumbing		Addition		Garage	
Occ. Code	101	Ttl Rooms Above #	4	Bedrooms Above #	2	Full Bath		Addition	No Additions	Garage	No garages
Occ. Descr.	Single-Family / Owner Occupied	Ttl Rooms Below #	0	Bedrooms Below #	0	Shower Stall Bath		Year Built		Style	
Year Built		Bsmt Fin Area #1				Toilet Room	1	EFA		W X L	
EFA / EFYr	/	Bsmt Fin Area #2				Lavatory		EFA Year		Area (SF)	
Arch. Dsgn		Bsmt Fin Area #3				Water Closet		Style		Year Built	
Style		Foundation	C Blk			Sink		Area (SF)		EFA	
AreaSF/TLA	/ 876	Exterior Walls	Wd Lap			Shower Stall/Tub		Condition		EFF Year	
GLA 1st/2nd	876 / 0	Roof	Asph / Gable			Mtl St Sh Bath					
		Interior Finish	Plas / Drwl			Mtl Stall Shower		Bsmt (SF)		Condition	
		Flooring	Carp / Vinyl			No Bathroom	1	NoBsmt Flr(SF)		Bsmt (SF)	
		Non-base Heating		Fireplace		Wet Bar		Heat		Qtrs Over	
		Floor/Wall #	1			Whirlpool Bathroom		AC		Qtrs Over (SF)	
		Pipeless #	0			Whirlpool Tub		Attic (SF)		Qtrs AC (SF)	
		Hand Fired (Y/N)	No			No Hot Water Tank					
Condition		Space Heat #	0			No Plumbing				Door Opnrs	
		Appliances				Sewer & Water Only				Bsmt Stalls	
Basement		Range Unit	Built-In Vacuums			Water Only w/Sink					
No Bsmt Flr.		Oven - Single	Intercom System			Hot Tub					
		Oven - Double	Bl Stereo			Bidet					
Heat		Dishwasher				FbglS Service Sink					
AC		Microwave				Urinal					
Attic		Trash Compactor				Sauna					
		Jennair				W'Pool Bath w/Shower					
		Security System				Water Only					
						No Tub/Shower					



Copyright © 1995-2014
Vanguard Appraisals, Inc.

Bldg / Addn 1 of 1	Description	Units	Year				
	101 — Single-Family / Owner Occupied	876					
	Adjustment for no base heat						
	Other Heat: Wall Furnace	1					
	Plumbing	2					

P:1	Yrd	Description	Units	Cond	Year
		1 — DWLG MOVED HERE		NML	1900

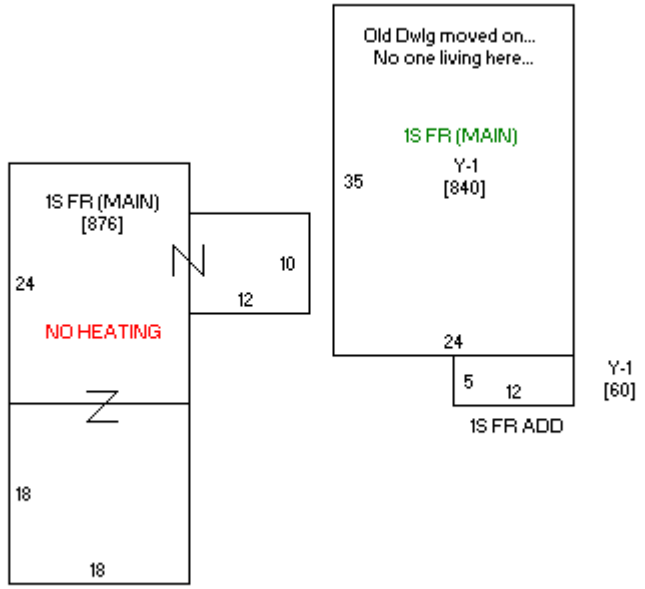

Sketch 1 of 1

