

Pin: 16-23-100-009
Sale Date: 11/09/15
Sale Price: \$90,000
Acres: 2.96 Net
Classification: Rural Residential

16-23-100-009

#7362.00

R-Res



12-18-14 - MKB
NEWER MTL ROOF ON
DWLG

G

1

3

2

4



LEGAL DESCRIPTION:

CLASS:

23-90-35 R RESIDENTIAL
NEWELL PROV. NEWELL
LOT A IN NW NW

-----		CSR'S	.00		
				CODE	VALUE ACRES
GROSS	3.54	CURRENT			
ROADS	.58	LAND	21,840		
D.D.		BLDG			
R.R.		DWLG	70,080(1)		
MISC					
		TOTAL	91,920		
NET	2.96				

=====		=====		=====	
		YEAR	2015		
		LAND	21,840	ROAD	.58
		BLDG			
		DWLG	70,080(1)		
		TOTAL	91,920		
		NET TX			

-----		-----		-----	
DEED HOLDER:	DATE REFER	CONTRACT HOLDER:	DATE REFER	YEAR	2014
ACKERMAN JEREMIA	12102015 3			LAND	21,000
				ROAD	.58
				BLDG	
2310 630TH ST				DWLG	67,380(1)
NEWELL IA 50568				TOTAL	88,380
				NET TX	

-----		-----		-----	
EVANS DAVID R	07072008 2			YEAR	2013
				LAND	21,000
				ROAD	.58
				BLDG	
2310 630TH ST				DWLG	67,380(1)
NEWELL IA 50568				TOTAL	88,380
				NET TX	

-----		-----		-----	
JEPPESON ELLSWORTH E				YEAR	2012
JEPPESON WANDA I				LAND	21,000
306 S NELSON				ROAD	.58
NEWELL IA 50568				BLDG	
				DWLG	67,380(1)
				TOTAL	88,380
				NET TX	

-----		-----		-----	
REMARKS:				YEAR	2011
				LAND	21,000
				ROAD	.58
				BLDG	
2 #081807-08 06-27-08 \$88,000 (D000)				DWLG	67,380(1)
3 W.D. #152874 11-09-15 \$90,000				TOTAL	88,380
				NET TX	

-----		-----		-----	
				YEAR	2010
				LAND	21,000
				ROAD	.58
				BLDG	
				DWLG	67,380(1)
				TOTAL	88,380
				NET TX	

Res. Structure		Finish				Plumbing		Addition		Garage	
Occ. Code	101	Ttl Rooms Above #	7	Bedrooms Above #	3	Full Bath	1	Addition	1 of 3	Garage	1 of 1
Occ. Descr.	Single-Family / Owner Occupied	Ttl Rooms Below #	0	Bedrooms Below #	0	Shower Stall Bath	1	Year Built	1920	Style	Det Frm
Year Built	1920	Bsmt Fin Area #1				Toilet Room		EFA	89	W X L	0' X 0'
EFA / EFYr	89 / 1920	Bsmt Fin Area #2				Lavatory		EFA Year	1920	Area (SF)	540
Arch. Dsgn	N/A	Bsmt Fin Area #3				Water Closet		Style	1 Sty Frm	Year Built	1930
Style	2 Story Frame	Foundation	C Blk			Sink		Area (SF)	216	EFA	79
AreaSF/TLA	896 / 2,683	Exterior Walls	Composite			Shower Stall/Tub		Condition	Below Normal	EFF Year	1930
GLA 1st/2nd	1,294 / 1,389	Roof	Mtl / Gable			Mtl St Sh Bath				Condition	Poor
		Interior Finish	Plas			Mtl Stall Shower		Bsmt (SF)		Bsmt (SF)	
		Flooring	Carp / Vinyl / Hdwd			No Bathroom		NoBsmt Flr(SF)		Qtrs Over	None
		Non-base Heating		Fireplace		Wet Bar		Heat	Elec - Basebd	Qtrs Over (SF)	
		Floor/Wall #	0			Whirlpool Bathroom		AC	No	Qtrs AC (SF)	
		Pipeless #	0			Whirlpool Tub		Attic (SF)			
		Hand Fired (Y/N)	No			No Hot Water Tank		See other pages for more additions.			
Condition	BL NML	Space Heat #	0			No Plumbing				Door Opnrs	
		Appliances				Sewer & Water Only				Bsmt Stalls	
Basement	Full	Range Unit	Built-In Vacuums			Water Only w/Sink					
No Bsmt Flr.	0	Oven - Single	Intercom System			Hot Tub					
Heat	Elec - Basebd	Oven - Double	Bl Stereo			Bidet					
AC	No	Dishwasher				Fbgls Service Sink					
Attic	Fully Finished 493SF	Microwave				Urinal					
		Trash Compactor				Sauna					
		Jennair				W'Pool Bath w/Shower					
		Security System				Water Only					
						No Tub/Shower					



Copyright © 1995-2014
Vanguard Appraisals, Inc.

Bldg / Addn	Description	Units	Year			
1 of 1	101 — Single-Family / Owner Occupied					
	2 Story Frame	896				
	Base Heat: Elec - Basebd					
	Add Fully Finished attic	493				
	Deck #1: Wood Deck-Low	392 SF				
	Plumbing	2				
1 of 3 Adtn	1 Story Frame	216 SF	1920			
2 of 3 Adtn	1 Story Frame	70 SF	1920			
3 of 3 Adtn	1 Story Frame	112 SF	1920			
	Garage: Det Frame 0' X 0'	540 SF	1930			

	Count	Ag Building Description	Units	Year
1 of 4 P:1	1	HEN HSE-FR @ .40 927-Shed	20' X 38' 760 SF	1900
2 of 4 P:2	1	ELEVATOR-CB @ .40 926-Crib	21' X 38' 798 SF	1900
3 of 4 P:3	1	CB @ .90 906-Barn - Flat	36' X 54' 1,944 SF	1900
4 of 4 P:4	1	MACH-FR @ .40 927-Shed	18' X 30' 540 SF	1900

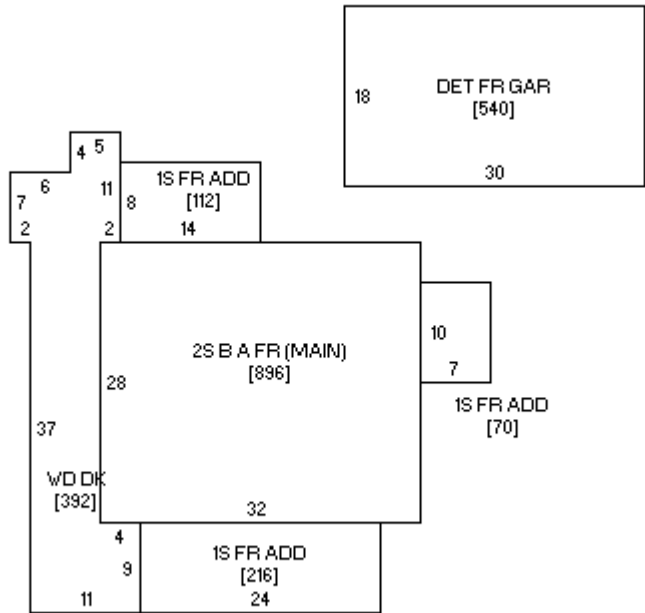

Sketch 1 of 1



Photo 1 of 2 09/16/2008



Photo 2 of 2 09/16/2008