

Pin: 11-12-200-006  
Sale Date: 04/23/16  
Sale Price: \$57,000  
Acres: 7.43 Net  
Classification: Change in use from Ag to Rural Residential

11-12-200-006

#8565.50

AG



11-12-200-005

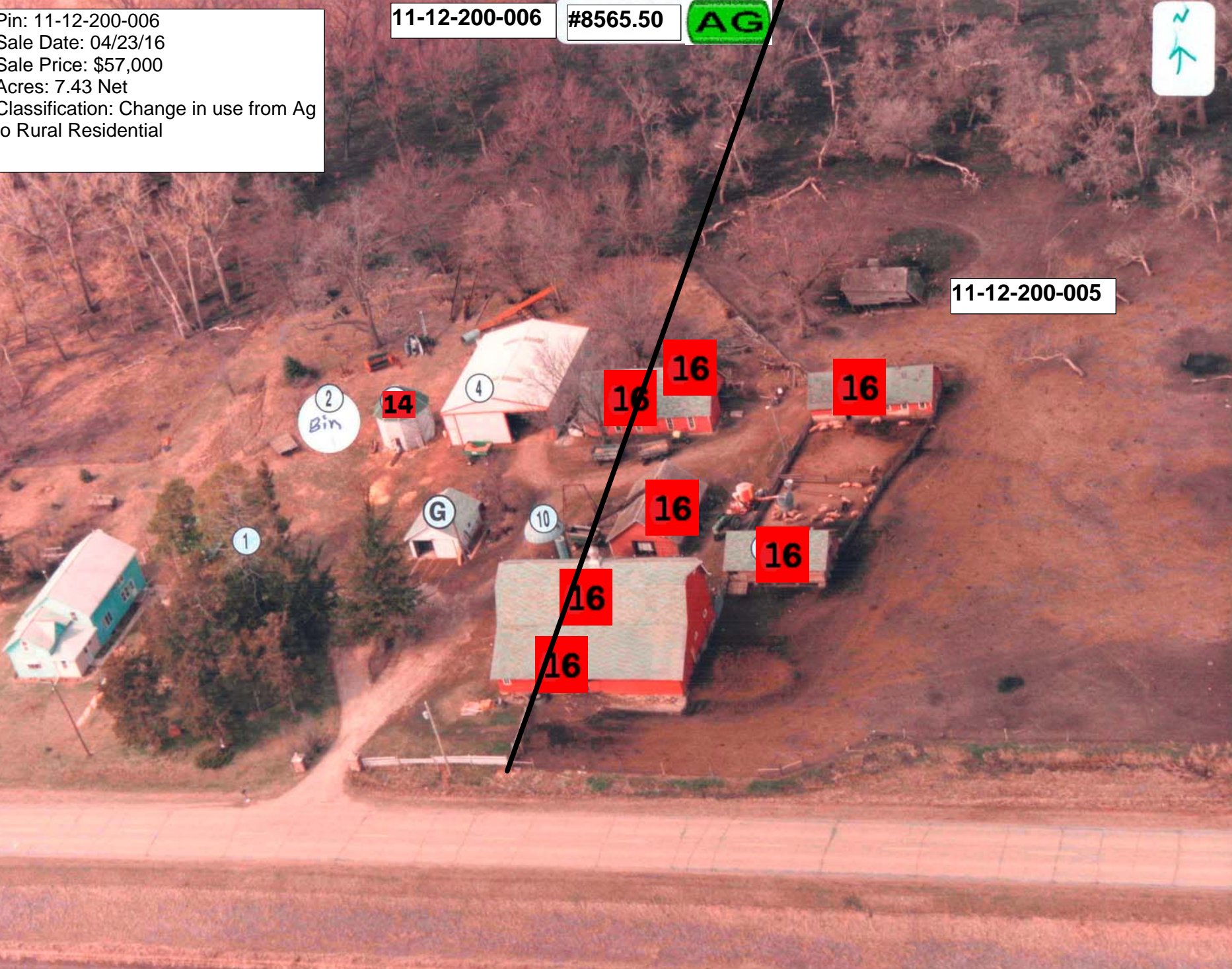

LEGAL DESCRIPTION:

CLASS:

12-91-36  
A.C.T. GRANT  
LOT E IN SW NE

A AGRICULTURE

-----		CSR'S	583.40	-----	
				CODE	VALUE ACRES
GROSS	8.06	CURRENT			
ROADS	.63	LAND	18,960		
D.D.		BLDG	2,870( 5)		
R.R.		DWLG	25,500( 1)		
MISC					
		TOTAL	47,330		
NET	7.43				

=====

YEAR	2016	REFER:	1
LAND	18,960		
BLDG	2,870( 5)		
DWLG	25,500( 1)		
TOTAL	47,330		
NET TX			

DEED HOLDER:

DATE REFER

CONTRACT HOLDER:

DATE REFER

YEAR 2015 REFER: 2

KELLY ANDREW J  
KELLY QUIN  
P O BOX 132  
ALBERT CITY IA 50510

06132016 3

LAND	18,960
BLDG	3,760(12)
DWLG	25,500( 1)
TOTAL	48,220
NET TX	

BUCHHOLZ RONALD

YEAR	
LAND	
BLDG	
DWLG	
TOTAL	
NET TX	

REMARKS:

- 1 !2016)SPLIT FORM -003 (06/13/16)
- 2 !2015)SPLIT FORM -003 (06/13/16)
- 3 WDJT #161192 04/23/16 \$57,000

YEAR	
LAND	
BLDG	
DWLG	
TOTAL	
NET TX	

YEAR	
LAND	
BLDG	
DWLG	
TOTAL	
NET TX	

1857 555TH ST, NEWELL

Deed: KELLY ANDREW J,KELLY QUIN

Map Area: GRANT-AG

Checks/Tags:

Contract:

Route: 911-001-410

Lister/Date: LF, 08/26/2008

CID#: 0000856550

Tax Dist: ACT GRANT

Review/Date: DS, 11/12/2008

DBA:

Plat Page: -

Entry Status: Inspected

MLS:

Subdiv: [NONE]

RURAL/AG DWELLING

Legal: 12-91-36 A.C.T. GRANT LOT E IN SW NE

Land										
Land Basis	Front	Rear	Side 1	Side 2	R. Lot	SF	Acres	Depth	EFF	Qual./Land
Ag Land							7.430			
Grand Total						323,650.80	7.430			

Street	Utilities	Zoning	Land Use
None	None	Not Applicable	Not Applicable

Sales				Building Permits				Values			
Date	\$ Amount	NUTC	Recording	Date	Number	Tag	\$ Amount	Reason			
04/23/2016	\$57,000	D26	160296								

Res. Structure		Finish				Plumbing		Addition		Garage	
Occ. Code	101	Ttl Rooms Above #	7	Bedrooms Above #	4	Full Bath	1	Addition	1 of 2	Garage	No garages
Occ. Descr.	Single-Family / Owner Occupied	Ttl Rooms Below #	0	Bedrooms Below #	0	Shower Stall Bath		Year Built	1900	Style	
Year Built	1900	Bsmt Fin Area #1				Toilet Room		EFA	109	W X L	
EFA / EfyR	109 / 1900	Bsmt Fin Area #2				Lavatory		EFA Year	1900	Area (SF)	
Arch. Dsgn	N/A	Bsmt Fin Area #3				Water Closet	1	Style	1 Sty Frm	Year Built	
Style	2 Story Frame	Foundation	Tile Blk			Sink	1	Area (SF)	256	EFA	
AreaSF/TLA	864 / 2,552	Exterior Walls	Wd Lap			Shower Stall/Tub		Condition	Very Poor	EFF Year	
GLA 1st/2nd	1,216 / 1,336	Roof	Asph / Gable			Mtl St Sh Bath		Bsmt (SF)		Condition	
Condition	V Poor	Interior Finish	Plas / Panel			Mtl Stall Shower		NoBsmt Flr(SF)		Bsmt (SF)	
Basement	Full	Flooring	Carp / Vinyl			No Bathroom		Heat	FHA - Gas	Qtrs Over	
No Bsmt Flr.	0	<b>Non-base Heating</b>		<b>Fireplace</b>		Wet Bar		AC	Yes	Qtrs Over (SF)	
Heat	FHA - Gas	Floor/Wall #	0			Whirlpool Bathroom		Attic (SF)	256	Qtrs AC (SF)	
AC	Yes	Pipeless #	0			Whirlpool Tub		See other pages for more additions.			
Attic	1/4 Finished 216SF	Hand Fired (Y/N)	No			No Hot Water Tank				Door Opnrs	
		Space Heat #	0			No Plumbing				Bsmt Stalls	
		<b>Appliances</b>				Sewer & Water Only					
		Range Unit	Built-In Vacuums			Water Only w/Sink					
		Oven - Single	Intercom System			Hot Tub					
		Oven - Double	BI Stereo			Bidet					
		Dishwasher				Fbgls Service Sink					
		Microwave				Urinal					
		Trash Compactor				Sauna					
		Jennair				W'Pool Bath w/Shower					
		Security System				Water Only					
						No Tub/Shower					



Bldg / Addn	Description	Units	Year
	101 — Single-Family / Owner Occupied		
	2 Story Frame	864	
	Base Heat: FHA - Gas		
	Add Central Air	864	
	Add 1/4 Finished attic	216	
#1	Porch: 1S Frame Enclosed	128 SF	
	Plumbing	3	
1 of 2 Adtn	1 Story Frame	256 SF	1900
2 of 2 Adtn	1 Story Frame	96 SF	1900

	Count	Ag Building Description	Units	Year					
1 of 5 P:1	1	SHOP FR @ .90 927-Shed	12' X 14' 168 SF	1900					
2 of 5 P:2	1	STORAGE 904-Bin - Stl. Grain Storage	18' X 18' 3,902 Bu	1974					
3 of 5 P:4	1	MTL POLE 925-Steel Utility Bldg	42' X 54' 2,268 SF	1979					
4 of 5 P:10	1	TILE @ SV 932-Silo - Conc	12' X 30' 2,726 Bu	1900					
5 of 5 P:13	1	FR @ NV 926-Crib	1' X 1' 1 SF	1900					



Yrd	Description	Units	Cond	Year
	1 — Shed		V Poor	1930

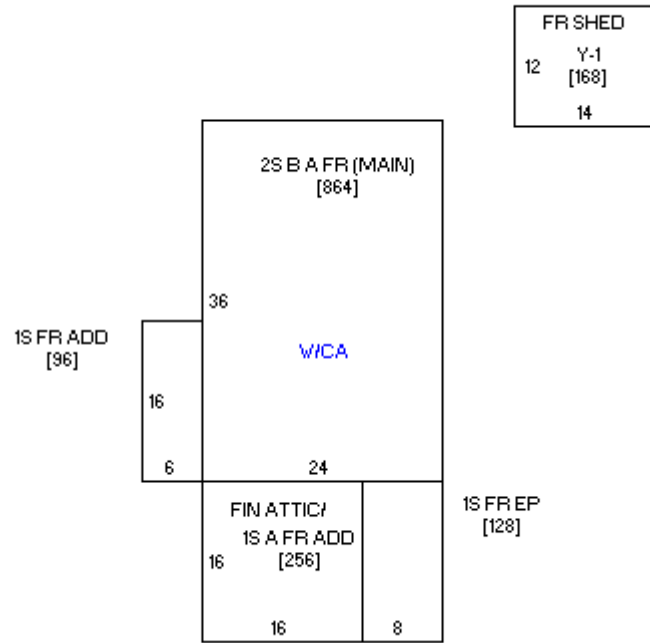

Sketch 1 of 1

