

Pin: 16-25-300-008
Sale Date: 07-20-16
Sale Price: \$82,000
Acres: 3.24 Net
Classification: Rural Residential

16-25-300-00

R-Res

#7380.50

WD
DK





Buena Vista County

Assessor
 P.O. Box 148
 215 E. 5th
 Storm Lake, Iowa 50588
 (712) 749-2543

PARRISH BEVERLY A
 2431 650TH ST
 NEWELL, IA 50568

**Assessor's Parcel Information Report
 For Parcel Number 1625300008**

Assessment Year: 2016
 Situs Address: 2431 650TH ST NEWELL
 Deeded Acres: 3.520
 Alternate Parcel Number: 0000738050

	Date	Book	Page	Instrument
Last Deeded:	7/22/2016	16	2024	162024
Last Contract:				
Legal:	25-90-35 NEWELL PROV. NEWELL LOT G IN SE SW			

Type	Owner	Percentage
Deed	PARRISH BEVERLY A	

	Valuations				Total	Counts					
	Land	Bldg	Dwlg			Acres	Unit	Bldg	Dwlg	Adj. CSR	Unadj. CSR
Tax District: 00380 - NEWELL PROV. NEWELL Property Class: Residential											
Full:	21,840	0	50,900		72,740	3.520	0.000	0	1	0.00	0.00
Exemptions:	0	0	0		0	0.280	0.000	0	0	0.00	0.00
Assessed:	21,840	0	50,900		72,740	3.240	0.000	0	1	0.00	0.00
Exemptions	Type	Value	Acres	Credits	Type	Value					
ROAD	ROAD RIGHT OF WAY	0	0.280		HOMESTEAD	4,850					

Res. Structure		Finish				Plumbing		Addition		Garage	
Occ. Code	101	Ttl Rooms Above #	6	Bedrooms Above #	3	Full Bath	1	Addition	1 of 3	Garage	1 of 1
Occ. Descr.	Single-Family / Owner Occupied	Ttl Rooms Below #	0	Bedrooms Below #	0	Shower Stall Bath	1	Year Built	1890	Style	Det Frm
Year Built	1890	Bsmt Fin Area #1				Toilet Room		EFA	119	W X L	0' X 0'
EFA / EFYr	119 / 1890	Bsmt Fin Area #2				Lavatory		EFA Year	1890	Area (SF)	720
Arch. Dsgn	N/A	Bsmt Fin Area #3				Water Closet		Style	1 Sty Frm	Year Built	2011
Style	1 1/2 Story Frame	Foundation	C Blk / Stn			Sink		Area (SF)	48	EFA	1
AreaSF/TLA	560 / 1,304	Exterior Walls	Stl			Shower Stall/Tub		Condition	Normal	EFF Year	2011
GLA 1st/2nd	912 / 392	Roof	Mtl / Gable			Mtl St Sh Bath		Bsmt (SF)		Condition	NML
Condition	NML	Interior Finish	Plas / Drwl / Panel			Mtl Stall Shower		NoBsmt Flr(SF)		Bsmt (SF)	
Basement	1/2	Flooring	Carp / Vinyl / Hdwd			No Bathroom		Heat	FHA - Gas	Qtrs Over	None
No Bsmt Flr.	0	Non-base Heating		Fireplace		Wet Bar		AC	Yes	Qtrs Over (SF)	
Heat	FHA - Gas	Floor/Wall #	0			Whirlpool Bathroom		Attic (SF)		Qtrs AC (SF)	
AC	Yes	Pipeless #	0			Whirlpool Tub		See other pages for more additions.			
Attic	None	Hand Fired (Y/N)	No			No Hot Water Tank				Door Opnrs	
		Space Heat #	0			No Plumbing				Bsmt Stalls	
		Appliances				Sewer & Water Only					
		Range Unit	Built-In Vacuums			Water Only w/Sink					
		Oven - Single	Intercom System			Hot Tub					
		Oven - Double	Bl Stereo			Bidet					
		Dishwasher				Fbgls Service Sink					
		Microwave				Urinal					
		Trash Compactor				Sauna					
		Jennair				W'Pool Bath w/Shower					
		Security System				Water Only					
						No Tub/Shower					



Copyright © 1995-2015
Vanguard Appraisals, Inc.

Bldg / Addn	Description	Units	Year
	101 — Single-Family / Owner Occupied		
	1 1/2 Story Frame	560	
	Adjustment for basement - 1/2		
	Base Heat: FHA - Gas		
	Add Central Air	560	
	Deck #1: Wood Deck-Med	112 SF	
	Plumbing	2	
1 of 3 Adtn	1 Story Frame	48 SF	1890
2 of 3 Adtn	1 Story Frame	192 SF	1890
3 of 3 Adtn	1 Story Frame	112 SF	1890
	Basement area	112 SF	
	Garage: Det Frame 0' X 0'	720 SF	2011

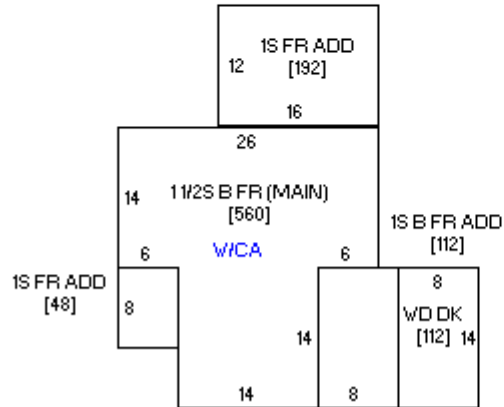
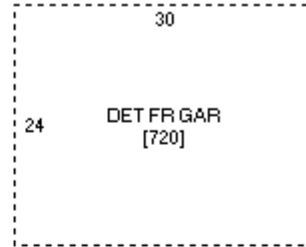

Sketch 1 of 1



Photo 1 of 4 01/21/2016



Photo 2 of 4 10/20/2011



Photo 3 of 4 09/16/2008



Photo 4 of 4 05/29/2007