

Pin: 09-27-201-004_005_007_009_012
Sale Date: 07/13/16
Sale Price: \$110,000
Classification: Rural Residential

09-27-201-004

R-Res

#11024.00



NOV 4 2004

Res. Structure		Finish				Plumbing		Addition		Garage	
Occ. Code	101	Ttl Rooms Above #	7	Bedrooms Above #	3	Full Bath	1	Addition	1 of 3	Garage	1 of 1
Occ. Descr.	Single-Family / Owner Occupied	Ttl Rooms Below #	0	Bedrooms Below #	0	Shower Stall Bath		Year Built	1886	Style	Att Frm
Year Built	1886	Bsmt Fin Area #1				Toilet Room		EFA	123	W X L	0' X 0'
EFA / EFYr	123 / 1886	Bsmt Fin Area #2				Lavatory		EFA Year	1886	Area (SF)	688
Arch. Dsgn	N/A	Bsmt Fin Area #3				Water Closet		Style	1 Sty Frm	Year Built	1886
Style	1 1/2 Story Frame	Foundation	C Blk			Sink	1	Area (SF)	443	EFA	123
AreaSF/TLA	384 / 1,656	Exterior Walls	Vinyl			Shower Stall/Tub		Condition	Above Normal	EFF Year	1886
GLA 1st/2nd	1,387 / 269	Roof	Asph / Gable			Mtl St Sh Bath		Bsmt (SF)		Condition	A NML
Condition	A NML	Interior Finish	Plas / Drwl			Mtl Stall Shower		NoBsmt Flr(SF)		Bsmt (SF)	
Basement	1/2	Flooring	Carp / Vinyl			No Bathroom		Heat	FHA - Gas	Qtrs Over	None
No Bsmt Flr.	0	Non-base Heating		Fireplace		Wet Bar		AC	Yes	Qtrs Over (SF)	
Heat	FHA - Gas	Floor/Wall #	0			Whirlpool Bathroom		Attic (SF)		Qtrs AC (SF)	
AC	Yes	Pipeless #	0			Whirlpool Tub		See other pages for more additions.			
Attic	None	Hand Fired (Y/N)	No			No Hot Water Tank				Door Opnrs	
		Space Heat #	0			No Plumbing				Bsmt Stalls	
		Appliances				Sewer & Water Only					
		Range Unit	Built-In Vacuums			Water Only w/Sink					
		Oven - Single	Intercom System			Hot Tub					
		Oven - Double	Bl Stereo			Bidet					
		Dishwasher				Fbgls Service Sink					
		Microwave				Urinal					
		Trash Compactor				Sauna					
		Jennair				W'Pool Bath w/Shower					
		Security System				Water Only					
						No Tub/Shower					



Bldg / Addn	Description	Units	Year			
	101 -- Single-Family / Owner Occupied					
	1 1/2 Story Frame	384				
	Adjustment for basement - 1/2					
	Base Heat: FHA - Gas					
	Add Central Air	384				
#1	Porch: 1S Brick Enclosed	72 SF				
	Deck #1: Wood Deck-Med	659 SF				
	Veneer #1 1/2 Story Brick	23.0 LF				
	Plumbing	2				
	Garage: Att Frame	688 SF	1886			
1 of 3	Adtn 1 Story Frame	443 SF	1886			
2 of 3	Adtn 1 Story Frame	144 SF	2000			
3 of 3	Adtn 1 Story Frame	416 SF	1886			

	Count	Ag Building Description	Units	Year
P:1	1	RABBIT HSE FR @ .90 927-Shed	20' X 52' 1,040 SF	1900

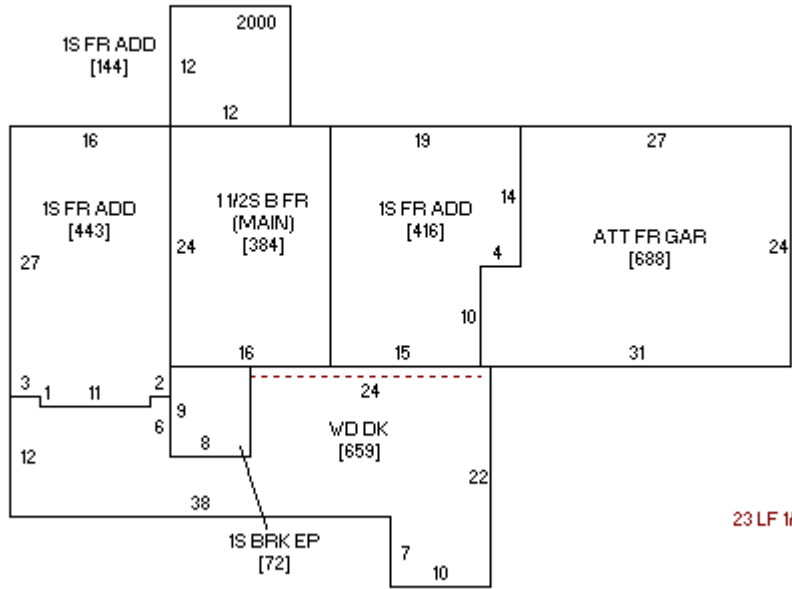

23 LF 1/2S BRK

Sketch 1 of 1



, ALTA

Deed: GIBSON FREDDIE JR, GIBSON TAMMIE

Map Area: NOKOMIS-RES

Checks/Tags:

Contract:

Route: 909-002-110

Lister/Date: LF, 09/10/2008

CID#: 0001102475

Tax Dist: ALTA NOKOMIS

Review/Date: DS, 11/05/2008

DBA:

Plat Page:

Entry Status: Inspected

MLS:

Subdiv: [NONE]

RURAL/RESIDENTIAL

Legal: 27-91-38 ALTA NOKOMIS PT SE COR NW NE (133'X200' EX S 12')

Land												
Land Basis	Front	Rear	Side 1	Side 2	R. Lot	SF	Acres	Depth	EFF	Qual./Land		
Site-Excess							0.570			NML		
Sub Total						24,829.20	0.570					
Grand Total						24,829.20	0.570					

Street	Utilities	Zoning	Land Use
None	None	Not Applicable	Not Applicable

Sales				Building Permits					Values			
Date	\$ Amount	NUTC	Recording	Date	Number	Tag	\$ Amount	Reason				
07/13/2016	\$0	D0	161913									
09/04/2009	\$0	D28	092776									
06/01/1999	\$0	D0	#991810									

VACANT LOT

, ALTA

Deed: GIBSON FREDDIE JR,GIBSON TAMMIE
 Contract:
 CID#: 0000201025
 DBA:
 MLS:

Map Area: ALTA-RES
 Route: 052-006-150
 Tax Dist: ALTA
 Plat Page:
 Subdiv: [NONE]

Checks/Tags:
 Lister/Date: LF, 05/02/2008
 Review/Date: TG, 09/18/2008
 Entry Status: Inspected

URBAN/RESIDENTIAL

Legal: 27-91-38 ALTA CORP. PT SE COR NW NE (12' X 133')

Land												
Land Basis	Front	Rear	Side 1	Side 2	R. Lot	SF	Acres	Depth	EFF	Qual./Land		
SqFt X Rate						1,596.00	0.037			R-20		
Grand Total						1,596.00	0.037					

Street		Utilities		Zoning		Land Use	
SqFt X Rate	Paved	City		Not Applicable		Not Applicable	

Sales				Building Permits					Values			
Date	\$ Amount	NUTC	Recording	Date	Number	Tag	\$ Amount	Reason				
07/13/2016	\$0	D0	161913									
09/04/2009	\$0	D28	092776									
06/01/1999	\$0	D0	#991810									

VACANT LOT

, ALTA

Deed: **GIBSON FREDDIE JR, GIBSON TAMMIE**
 Contract:
 CID#: **0001102485**
 DBA:
 MLS:

Map Area: **NOKOMIS-RES**
 Route: **909-002-130**
 Tax Dist: **ALTA NOKOMIS**
 Plat Page:
 Subdiv: **[NONE]**

Checks/Tags:
 Lister/Date: **LF, 09/10/2008**
 Review/Date: **DS, 11/05/2008**
 Entry Status: **Inspected**

RURAL/RESIDENTIAL

Legal: 27-91-38 ALTA NOKOMIS PT SE COR NW NE (145' X 279.7')

Land											
Land Basis	Front	Rear	Side 1	Side 2	R. Lot	SF	Acres	Depth	EFF	Qual./Land	
Site-Excess							0.000			None	
Excess 1							0.940			NML	
Sub Total						40,946.40	0.940				
Grand Total						40,946.40	0.940				

Street	Utilities	Zoning	Land Use
None	None	Not Applicable	Not Applicable

Sales				Building Permits				Values				
Date	\$ Amount	NUTC	Recording	Date	Number	Tag	\$ Amount	Reason				
07/13/2016	\$0	D0	191913									
09/04/2009	\$0	D28	092776									
06/01/1999	\$10,000	D0	#991810									

VACANT LOT

