

#12107.60

AG

E  
↑

Pin: 01-28-400-004/005  
Sale Date: 07/21/17  
Sale Price: \$62,000  
Net Acres: 4.80  
Classification - Change in Use  
from Ag to Rural Residential

01-28-400-004/005



4689 40TH AVE, ALTA

Deed: **ANDERSON DAWN R**

Map Area: **BROOKE-AG**

Checks/Tags:

Contract:

Route: **901-001-570**

Lister/Date: **CL, 07/21/2008**

CID#: **1210760**

Tax Dist: **SV BROOKE**

Review/Date: **DS, 10/15/2008**

DBA:

Plat Page:

Entry Status: **Inspected**

MLS: **18986**

Subdiv: **[NONE]**

**RURAL / AG DWELLING**

Legal: 28-93-38 SIOUX VALLEY BROOKE PT. SE SE

**Land**

| Land Basis         | Front | Rear | Side 1 | Side 2 | R. Lot | SF         | Acres |  |  |  |  |  |  |  |  |  |
|--------------------|-------|------|--------|--------|--------|------------|-------|--|--|--|--|--|--|--|--|--|
| <b>Lump Sum</b>    |       |      |        |        |        | 0.00       | 0.000 |  |  |  |  |  |  |  |  |  |
| <b>BS</b>          |       |      |        |        |        |            | 4.420 |  |  |  |  |  |  |  |  |  |
| <b>Grand Total</b> |       |      |        |        |        | 192,535.20 | 4.420 |  |  |  |  |  |  |  |  |  |

|                 | <b>Street</b> | <b>Utilities</b> | <b>Zoning</b>  | <b>Land Use</b> |
|-----------------|---------------|------------------|----------------|-----------------|
| <b>Lump Sum</b> | Gravel        | Septic / Well    | Not Applicable | Non Applicable  |
| <b>BS</b>       | None          | None             | Not Applicable | Building Site   |

| <b>Sales</b> |           |      |           | <b>Building Permits</b> |        |     |           |        | <b>Values</b> |  |  |               |  |
|--------------|-----------|------|-----------|-------------------------|--------|-----|-----------|--------|---------------|--|--|---------------|--|
| Date         | \$ Amount | NUTC | Recording | Date                    | Number | Tag | \$ Amount | Reason | Type          |  |  | St. Equalized |  |
| 07/21/2017   | \$62,000  | D15  | 171900    |                         |        |     |           |        | Land          |  |  | \$5,580       |  |
|              |           |      |           |                         |        |     |           |        | LandC         |  |  | \$0           |  |
|              |           |      |           |                         |        |     |           |        | Dwlg          |  |  | \$42,790      |  |
|              |           |      |           |                         |        |     |           |        | Impr          |  |  | \$4,500       |  |
|              |           |      |           |                         |        |     |           |        | Total         |  |  | \$52,870      |  |

| Res. Structure |                                   | Finish                  |                  |                  |   | Plumbing             |   | Addition                            |              | Garage             |            |
|----------------|-----------------------------------|-------------------------|------------------|------------------|---|----------------------|---|-------------------------------------|--------------|--------------------|------------|
| Occ. Code      | 101                               | Ttl Rooms Above #       | 7                | Bedrooms Above # | 3 | Full Bath            |   | Addition                            | 1 of 3       | Garage             | No garages |
| Occ. Descr.    | Single-Family /<br>Owner Occupied | Ttl Rooms Below #       | 0                | Bedrooms Below # | 0 | Shower Stall Bath    | 1 | Year Built                          | 1900         | Style              |            |
| Year Built     | 1900                              |                         |                  |                  |   | Toilet Room          |   | EFA                                 | 109          | W X L              |            |
| EFA / EFYr     | 109 / 1900                        |                         |                  |                  |   | Lavatory             |   | EFA Year                            | 1900         | Area (SF)          |            |
| Arch. Dsgn     | N/A                               | Foundation              | C Blk            |                  |   | Water Closet         |   | Style                               | 1 Sty Frm    | Year Built         |            |
| Style          | 2 Story Frame                     | Exterior Walls          | Wd Lap           |                  |   | Sink                 |   | Area (SF)                           | 64           | EFA                |            |
| AreaSF/TLA     | 640 / 1,732                       | Roof                    | Asph / Gable     |                  |   | Shower Stall/Tub     |   | Condition                           | Below Normal | EFF Year           |            |
| GLA 1st/2nd    | 1,092 / 640                       | Interior Finish         | Plas / Panel     |                  |   | Mtl St Sh Bath       |   | Bsmt (SF)                           |              | Condition          |            |
|                |                                   | Flooring                | Carp             |                  |   | Mtl Stall Shower     |   | NoBsmt Flr(SF)                      |              | Bsmt (SF)          |            |
|                |                                   | <b>Non-base Heating</b> |                  | <b>Fireplace</b> |   | No Bathroom          | 1 | Heat                                | Yes          | Qtrs Over          |            |
|                |                                   | Floor/Wall #            | 0                |                  |   | Wet Bar              |   | AC                                  | Yes          | Qtrs Over (SF)     |            |
|                |                                   | Pipeless #              | 0                |                  |   | Whirlpool Bathroom   |   | Attic (SF)                          |              | Qtrs AC (SF)       |            |
|                |                                   | Hand Fired (Y/N)        | No               |                  |   | Whirlpool Tub        |   | See other pages for more additions. |              |                    |            |
| Condition      | BL NML                            | Space Heat #            | 0                |                  |   | No Hot Water Tank    |   |                                     |              | Door Opnrs         |            |
|                |                                   | <b>Appliances</b>       |                  |                  |   | No Plumbing          |   |                                     |              | Stalls- Bsmt / Std |            |
| Basement       | Full                              | Range Unit              | Built-In Vacuums |                  |   | Sewer & Water Only   |   |                                     |              |                    |            |
| No Bsmt Flr.   | 0                                 | Oven - Single           | Intercom System  |                  |   | Water Only w/Sink    |   |                                     |              |                    |            |
| Heat           | Yes                               | Oven - Double           | Bl Stereo        |                  |   | Hot Tub              |   |                                     |              |                    |            |
| AC             | Yes                               | Dishwasher              |                  |                  |   | Bidet                |   |                                     |              |                    |            |
| Attic          | None                              | Microwave               |                  |                  |   | FbglS Service Sink   |   |                                     |              |                    |            |
|                |                                   | Trash Compactor         |                  |                  |   | Urinal               |   |                                     |              |                    |            |
|                |                                   | Jennair                 |                  |                  |   | Sauna                |   |                                     |              |                    |            |
|                |                                   | Security System         |                  |                  |   | W'Pool Bath w/Shower |   |                                     |              |                    |            |
|                |                                   |                         |                  |                  |   | Water Only           |   |                                     |              |                    |            |
|                |                                   |                         |                  |                  |   | No Tub/Shower        |   |                                     |              |                    |            |



| Bldg / Addn | Description                           | Units  | Year |  |  |  |
|-------------|---------------------------------------|--------|------|--|--|--|
|             | 101 -- Single-Family / Owner Occupied |        |      |  |  |  |
|             | 2 Story Frame                         | 640    |      |  |  |  |
|             | Base Heat                             |        |      |  |  |  |
|             | Add Central Air                       | 640    |      |  |  |  |
| #1          | Porch: 1S Frame Screen                | 420 SF |      |  |  |  |
|             | Plumbing                              | 2      |      |  |  |  |
| 1 of 3      | Adtn 1 Story Frame                    | 64 SF  | 1900 |  |  |  |
| 2 of 3      | Adtn 1 Story Frame                    | 12 SF  | 1900 |  |  |  |
| 3 of 3      | Adtn 1 Story Frame                    | 376 SF | 1900 |  |  |  |

|               | Count | Ag Building Description                 | Units                     | Year |
|---------------|-------|---|---------------------------|------|
| 1 of 8<br>P:1 | 1     | QUONSET<br>925-Steel Utility Bldg       | 42' X 50' 2,100 SF        | 1977 |
| 2 of 8<br>P:2 | 1     | STORAGE<br>904-Bin - Stl. Grain Storage | 36' X 18' X 18' 16,195 Bu | 1979 |
| 3 of 8<br>P:3 | 1     | OP MTL @ .40<br>927-Shed                | 22' X 24' 528 SF          | 1900 |
| 4 of 8<br>P:4 | 1     | OP MTL @ NV<br>927-Shed                 | 22' X 48' 1,056 SF        | 1900 |
| 5 of 8<br>P:6 | 1     | DC C/S<br>932-Silo - Conc               | 14' X 40' X 40' 4,948 Bu  | 1900 |
| 6 of 8<br>P:7 | 1     | FEED FR @ .40<br>927-Shed               | 10' X 24' 240 SF          | 1900 |
| 7 of 8<br>P:8 | 1     | OP FR @ .40<br>927-Shed                 | 18' X 32' 576 SF          | 1900 |
| 8 of 8<br>P:9 | 1     | MACH FR @ .90<br>927-Shed               | 24' X 40' 960 SF          | 1900 |

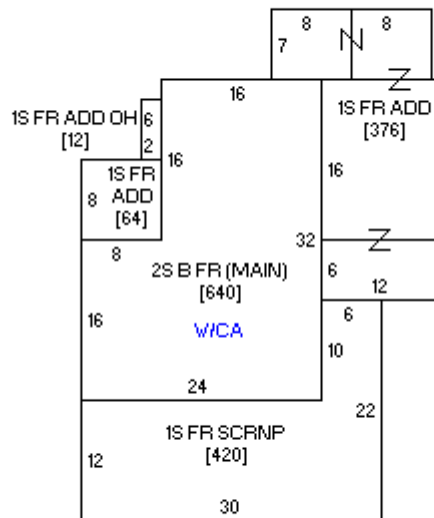



Deed: **ANDERSON DAWN R**  
 Contract:  
 CID#: **0001210750**  
 DBA:  
 MLS:

Map Area: **BROOKE-AG**  
 Route: **000-000-000**  
 Tax Dist: **SV BROOKE**  
 Plat Page:  
 Subdiv: **[NONE]**

Checks/Tags:  
 Lister/Date:  
 Review/Date:  
 Entry Status:

**RURAL / AG LAND**

Legal: 28-93-38 SIOUX VALLEY BROOKE PT NE SE

| Land               |       |      |        |        |        |           |       |  |  |  |  |  |  |
|--------------------|-------|------|--------|--------|--------|-----------|-------|--|--|--|--|--|--|
| Land Basis         | Front | Rear | Side 1 | Side 2 | R. Lot | SF        | Acres |  |  |  |  |  |  |
| <b>BS</b>          |       |      |        |        |        | 16,552.80 | 0.380 |  |  |  |  |  |  |
| <b>Grand Total</b> |       |      |        |        |        | 16,552.80 | 0.380 |  |  |  |  |  |  |

| Street           | Utilities | Zoning         | Land Use      |
|------------------|-----------|----------------|---------------|
| <b>BS</b>   None | None      | Not Applicable | Building Site |

| Sales      |           |      |           | Building Permits |        |     |           |        | Values |  |  |               |
|------------|-----------|------|-----------|------------------|--------|-----|-----------|--------|--------|--|--|---------------|
| Date       | \$ Amount | NUTC | Recording | Date             | Number | Tag | \$ Amount | Reason | Type   |  |  | St. Equalized |
| 07/21/2017 | \$0       | D0   | 171900    |                  |        |     |           |        | Land   |  |  | \$480         |
|            |           |      |           |                  |        |     |           |        | LandC  |  |  | \$0           |
|            |           |      |           |                  |        |     |           |        | Dwlg   |  |  | \$0           |
|            |           |      |           |                  |        |     |           |        | Impr   |  |  | \$0           |
|            |           |      |           |                  |        |     |           |        | Total  |  |  | \$480         |