

Res. Structure		Finish				Plumbing		Addition		Garage	
Occ. Code	101	Ttl Rooms Above #	5	Bedrooms Above #	3	Full Bath	1	Addition	No Additions	Garage	1 of 1
Occ. Descr.	Single-Family / Owner Occupied	Ttl Rooms Below #	0	Bedrooms Below #	0	Shower Stall Bath		Year Built		Style	Att Frm
Year Built	2003					Toilet Room	1	EFA		W X L	0' X 0'
EFA / EFYr	6 / 2003					Lavatory		EFA Year		Area (SF)	910
Arch. Dsgn	N/A	Foundation	Conc			Water Closet		Style		Year Built	2003
Style	1 Story Frame	Exterior Walls	Other			Sink	1	Area (SF)		EFA	6
AreaSF/TLA	2,318 / 2,318	Roof	Asph / Hip			Shower Stall/Tub	1	Condition		EFF Year	2003
GLA 1st/2nd	2,318 / 0	Interior Finish	Drwl			Mtl St Sh Bath		Bsmt (SF)		Condition	NML
		Flooring	Carp / Ceramic			Mtl Stall Shower		NoBsmt Flr(SF)		Bsmt (SF)	
		Non-base Heating		Fireplace		No Bathroom		Heat		Qtrs Over	None
		Floor/Wall #	0	Masonry, 1 Sty	1	Wet Bar		AC		Qtrs Over (SF)	
		Pipeless #	0			Whirlpool Bathroom	1	Attic (SF)		Qtrs AC (SF)	
		Hand Fired (Y/N)	No			Whirlpool Tub				Door Opnrs	
Condition	NML	Space Heat #	0			No Hot Water Tank				Stalls- Bsmt / Std	
		Appliances				No Plumbing					
Basement	Full	Range Unit	Built-In Vacuums			Sewer & Water Only					
No Bsmt Flr.	0	Oven - Single	Intercom System			Water Only w/Sink					
Heat	FHA - Gas	Oven - Double	Bl Stereo			Hot Tub					
AC	Yes	Dishwasher				Bidet					
Attic	None	Microwave				Fbgls Service Sink					
		Trash Compactor				Urinal					
		Jennair				Sauna					
		Security System				W'Pool Bath w/Shower					
						Water Only					
						No Tub/Shower					

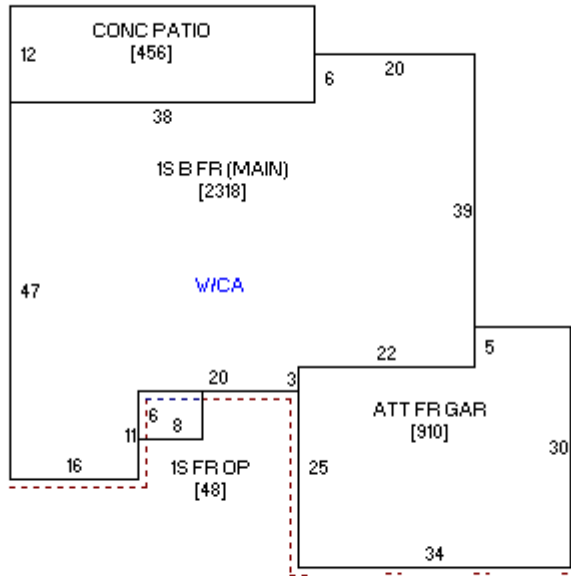

Bldg / Addn	Description	Units	Year
	101 — Single-Family / Owner Occupied		
	1 Story Frame	2,318	
	Base Heat: FHA - Gas		
	Add Central Air	2,318	
#1	Porch: 1S Frame Open	48 SF	
	Deck #1: Concrete Patio-Med	456 SF	
	Veneer #1 1/2 Story Brick	70.0 LF	
	Veneer #2 1 Story Brick	8.0 LF	
	Plumbing	5	
#1	Fireplace: Masonry, 1 Story	1	
	Garage: Att Frame	910 SF	2003

	Count	Ag Building Description	Units	Year
1 of 2 P:2	1	MTL POLE 925-Steel Utility Bldg	48' X 75' 3,600 SF	2003
2 of 2 P:3	1	MTL POLE @ .90 927-Shed	28' X 60' 1,680 SF	1900



70 LF 1/2S BRK
8 LF 1S BRK

TVC 12/18/03
Sketch 1 of 1

