

PIN: 16-04-300-005  
Sale Date: 7/31/2019  
Sale Price: \$175,000  
Acres: 9.25  
Classification: Agriculture

16-04-300-005

#7219.00



4

5

7 Shed

New Mtl Siding

ASPH  
RF/WD  
DK

3

Re-tinned

2

#8-Att  
Mach  
Shed

1

Att  
Shed  
6



Res. Structure		Finish				Plumbing		Addition		Garage	
Occ. Code	101	Ttl Rooms Above #	6	Bedrooms Above #	3	Full Bath	1	Addition	1 of 2	Garage	No garages
Occ. Descr.	Single-Family / Owner Occupied	Ttl Rooms Below #	0	Bedrooms Below #	0	Shower Stall Bath		Year Built	1890	Style	
Year Built	1890					Toilet Room		EFA	129	W X L	
EFA / EFYr	129 / 1890					Lavatory		EFA Year	1890	Area (SF)	
Arch. Dsgn	N/A	Foundation	C Blk			Water Closet		Style	1 Sty Fr.	Year Built	
Style	1 1/2 Story Frame	Exterior Walls	Vinyl			Sink		Area (SF)	112	EFA	
AreaSF/TLA	616 / 1,415	Roof	Asph / Gable			Shower Stall/Tub		Condition	Poor	EFF Year	
GLA 1st/2nd	984 / 431	Interior Finish	Plas			Mtl St Sh Bath		Bsmt (SF)	112	Condition	
		Flooring	Carp / Vinyl			Mtl Stall Shower		NoBsmt Flr(SF)		Bsmt (SF)	
		<b>Non-base Heating</b>		<b>Fireplace</b>		No Bathroom		Heat	FHA - Gas	Qtrs Over	
		Floor/Wall #	0			Wet Bar		AC	Yes	Qtrs Over (SF)	
		Pipeless #	0			Whirlpool Bathroom		Attic (SF)		Qtrs AC (SF)	
		Hand Fired (Y/N)	No			Whirlpool Tub		See other pages for more additions.			
Condition	Poor	Space Heat #	0			No Hot Water Tank				Door Opnrs	
		<b>Appliances</b>				No Plumbing				Stalls- Bsmt / Std	
Basement	Full	Range Unit	Built-In Vacuums			Sewer & Water Only					
No Bsmt Flr.	0	Oven - Single	Intercom System			Water Only w/Sink					
Heat	FHA - Gas	Oven - Double	Bl Stereo			Hot Tub					
AC	Yes	Dishwasher				Bidet					
Attic	None	Microwave				Fbgls Service Sink					
		Trash Compactor				Urinal					
		Jennair				Sauna					
		Security System				W'Pool Bath w/Shower					
						Water Only					
						No Tub/Shower					



Bldg/ Addn	Description	Units	Year			
	101 — Single-Family / Owner Occupied					
	1 1/2 Story Frame	616				
	Base Heat: FHA - Gas					
	Add Central Air	616				
#1	Porch: 1S Frame Open	64 SF				
	Deck #1: Wood Deck-Med	240 SF				
	Deck #2: Asph/Wd Roof OH-Med	240 SF				
1 of 2	Adtn 1 Story Frame	112 SF	1890			
	Basement area	112 SF				
2 of 2	Adtn 1 Story Frame	256 SF	1987			



	Count	Ag Building Description	Units	Year
1 of 8 P:1	1	POLE-FR @ .90 915-Barn - Small	42' X 50' 2,100 SF	1900
2 of 8 P:2	1	DBL-FR @ .90 924-Machine or Utility Bldg	24' X 48' 1,152 SF	1900
3 of 8 P:3	1	ATT-FR @ .90 927-Shed	6' X 6' 36 SF	1900
4 of 8 P:4	1	MACH-FR @ .90 927-Shed	26' X 50' 1,300 SF	1900
5 of 8 P:5	1	HEN HSE-FR @ .90 927-Shed	24' X 24' 576 SF	1900
6 of 8 P:6	1	MTL @ .40 908-Lean-To	12' X 24' 288 SF	1994
7 of 8 P:7	1	FR P SHED @ .90 927-Shed	20' X 48' 960 SF	1996
8 of 8 P:8	1	ATT MACH SHED MTL P FR; Pole Frame; En; 925-Steel Utility Bldg	40' X 60' 2,400 SF	2003

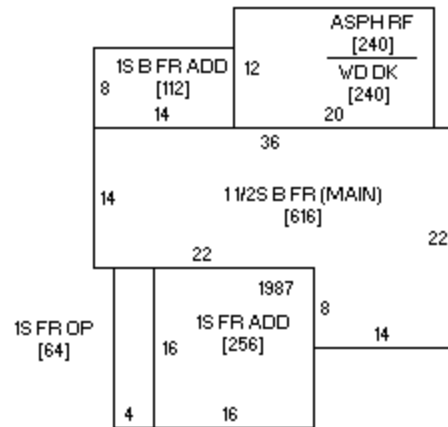



Photo 1 of 1 09/09/2008